

ROCKET  
SCIENCE



# SCHEDULE FOR TODAY

---

01

The cool  
physics and  
maths

02

Making  
rockets

03

Launching the  
rockets

04

Competition



Who is he?

---



Who is he?



*The story might be a bit exaggerated —science discoveries are actually built on many people's ideas and experiments over time.*



Newton also discovered this:

# THIRD LAW OF MOTION

*“For every action (force) in nature there is an equal and opposite reaction.”*

**Action:** The air is pushing the ballon.  
**Reaction:** The ballon is trying to squeeze the air out.  
If you let it go, the ballon will...





# What is the action and reaction in these cases?

- Case 1: Push the table forward. Do you feel the table is also pushing you? Which direction?
- Case 2: You and your friend are both standing on a skateboard. If you push your friend, what will happen to your friend? What about you? Which direction are you going? If regardless the friction, how far will you two go?
- Case 3: If you throw a bouncy ball to the floor, what will happen to the ball?



# Newton's Third Law



## Rocket Engine Thrust

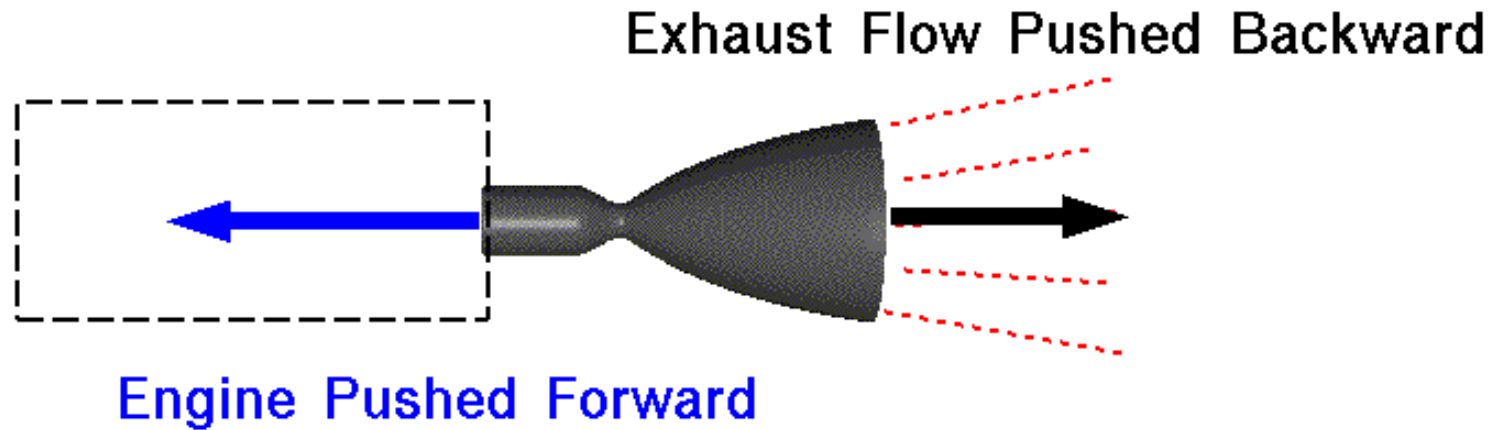

*For every action, there is an equal and opposite re-action.*



[Blastoff! SpaceX launches Starship on Flight 8 — booster caught, ship spins out of control](#)

# 1. MAKING THE ROCKET



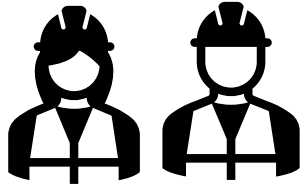

## SAFETY RISKS

- Paper cuts
- Cuts with tape dispensers
- Careful with sharp surfaces
- Scissors use



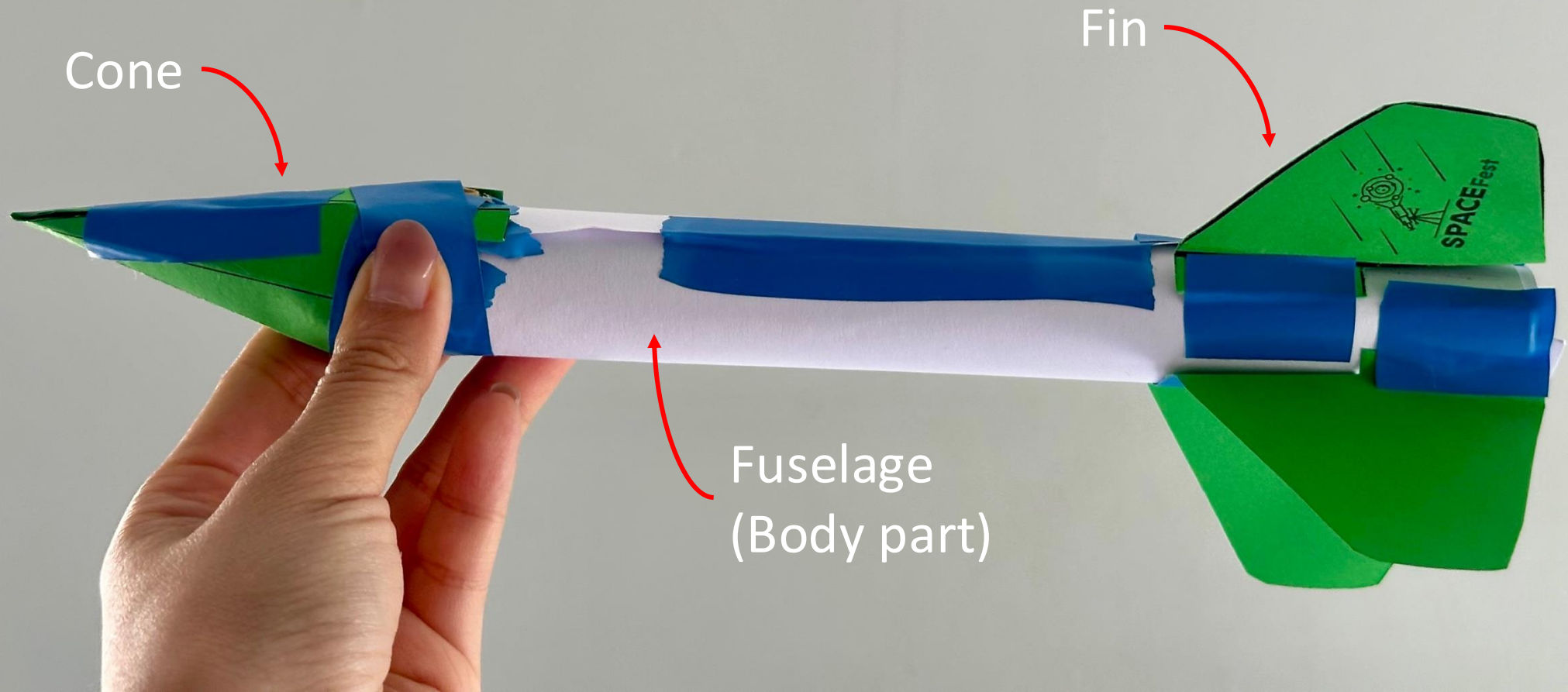

PARTS OF A ROCKET

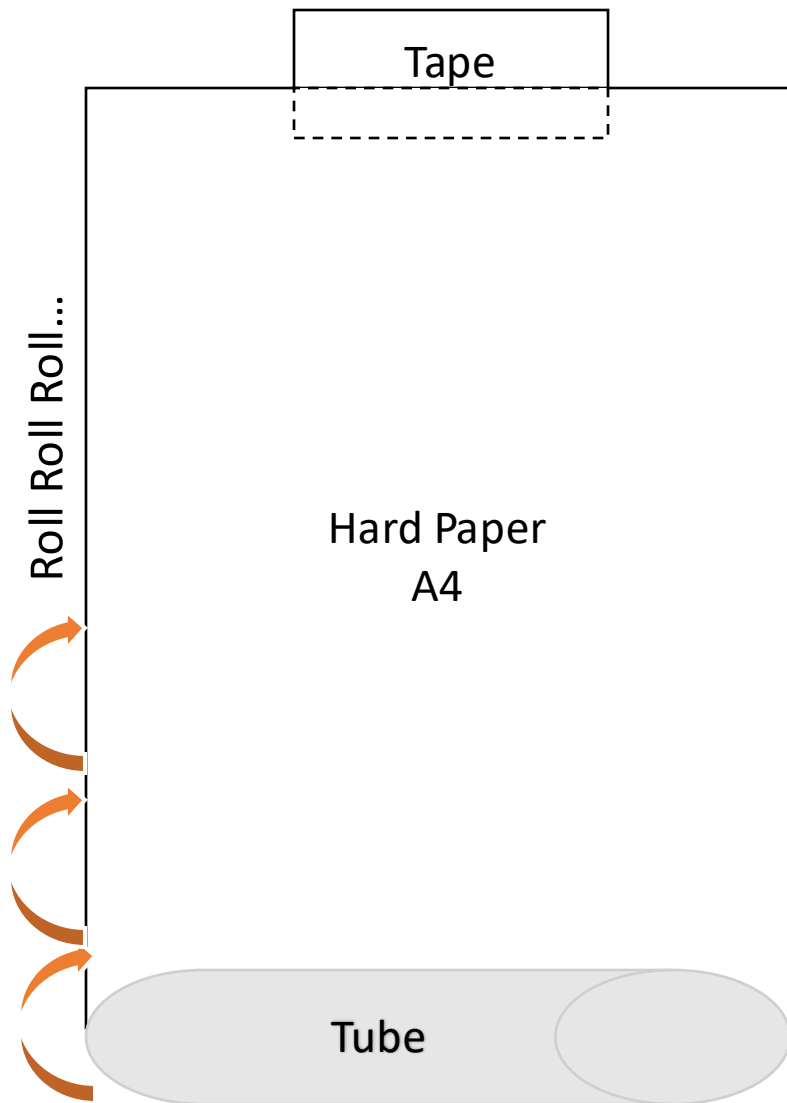

1. Put a piece of tape at the top of the A4 paper. Turn the paper back to Put the tube at the bottom.

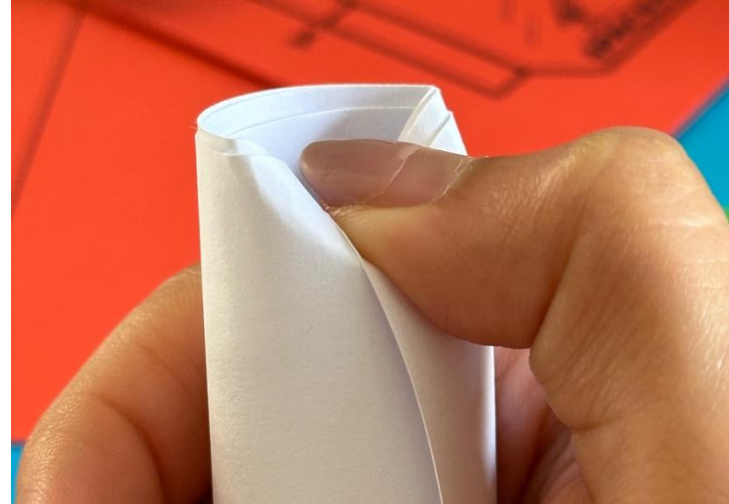

!! Make sure no air can leak out from your top end !!

2. Pull out the tube, around 1-2 cm to the top end of the paper cylinder. Use your thumb to press the top down. Use tapes to close it.

\* We put blue tapes here to help you see them better. You can use transparent tapes to make it more beautiful.



## LET'S DECORATE THE FUSELAGE

---

Don't put too much tape!

Make sure there is space for decoration!

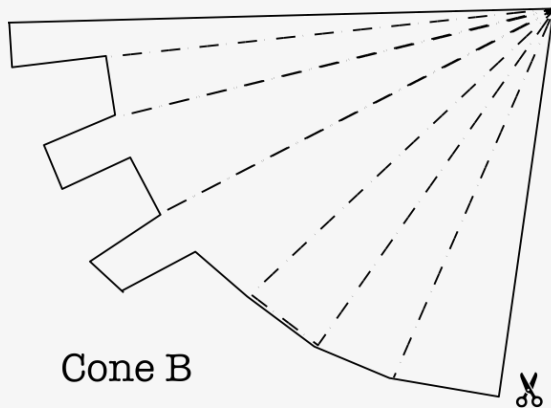
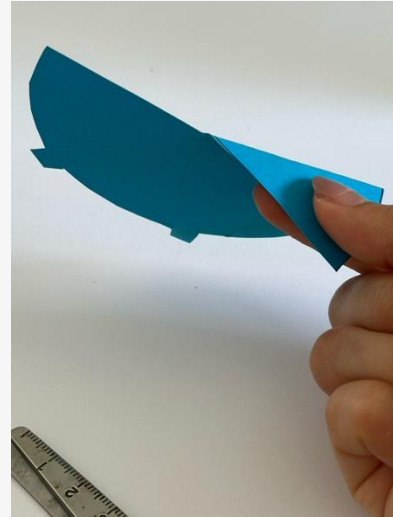
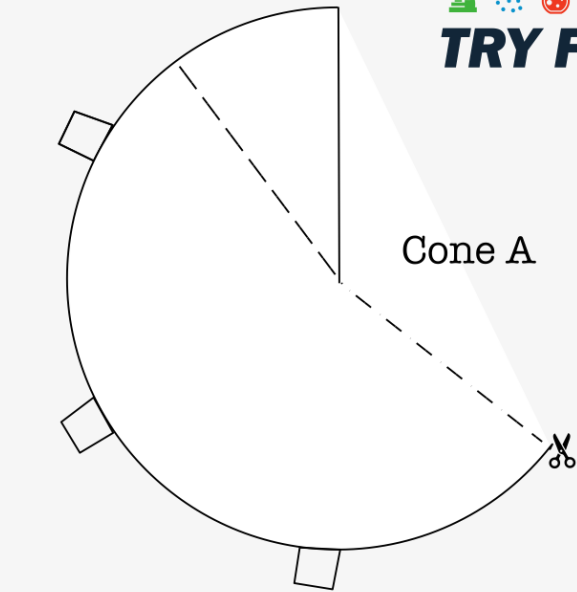

## Making the nose cone

3. Choose your favorite design (A or B). Carefully cut along the outer curve. You'll get a sector (a "pizza slice" shape).
4. Fold the paper along the dashed/solid lines shown in the diagram. This line will help you form a sharp point. You can use the end of the scissor to make a curve along the line, which will help you fold it easier.

\*Cone A looks short and wide. Cone B looks tall and narrow.

**\*Careful of the sharp tip!**

## 5. Roll the Sector into a Cone Shape

Bring the two straight edges together so that the paper curves into a **cone shape**. Overlap the edges slightly to make the tip pointy. This may take a little adjusting.

## 6. Attach the cone to the body

Put the cone on **the top end** of the body part. If the cone is too wide, roll tighter; if too narrow, loosen slightly. Once the desired shape is achieved, **put tape** along the overlapping edges to hold the cone in place. You might need your friend to help you hold the cone straight.

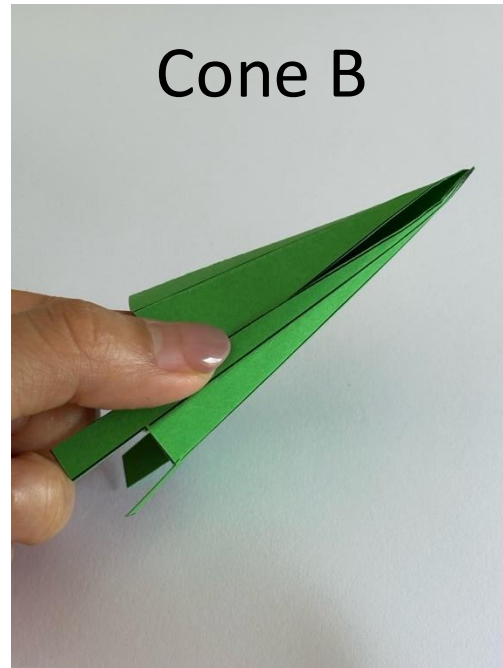
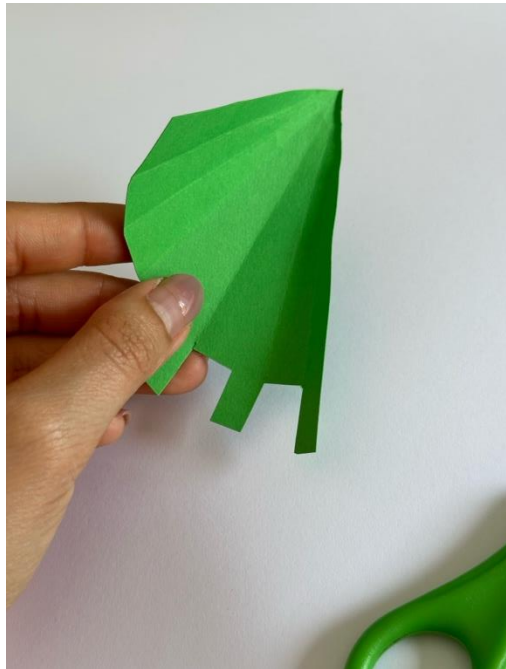

Design A

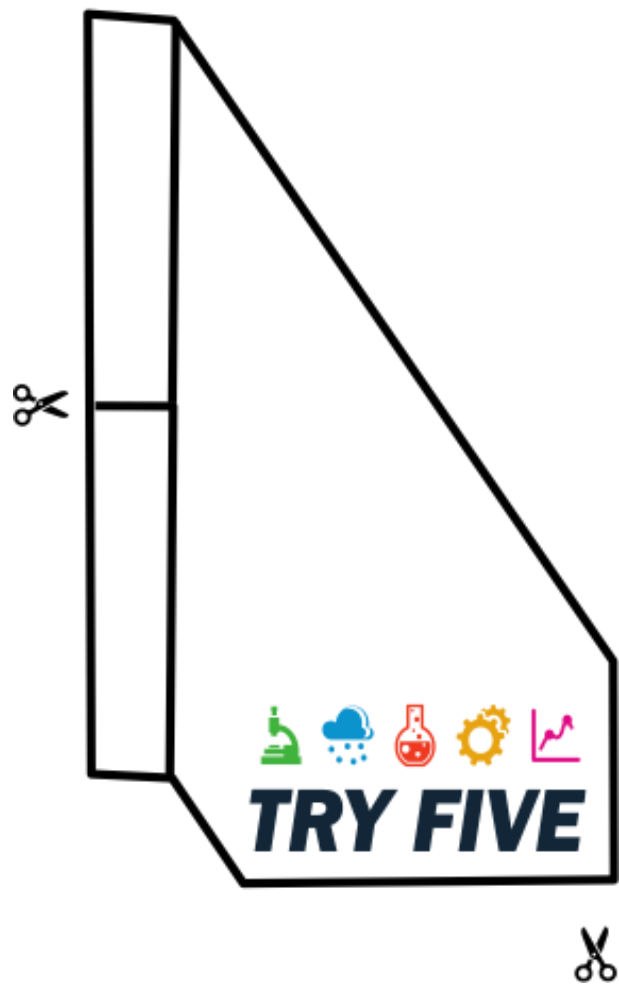

Design B

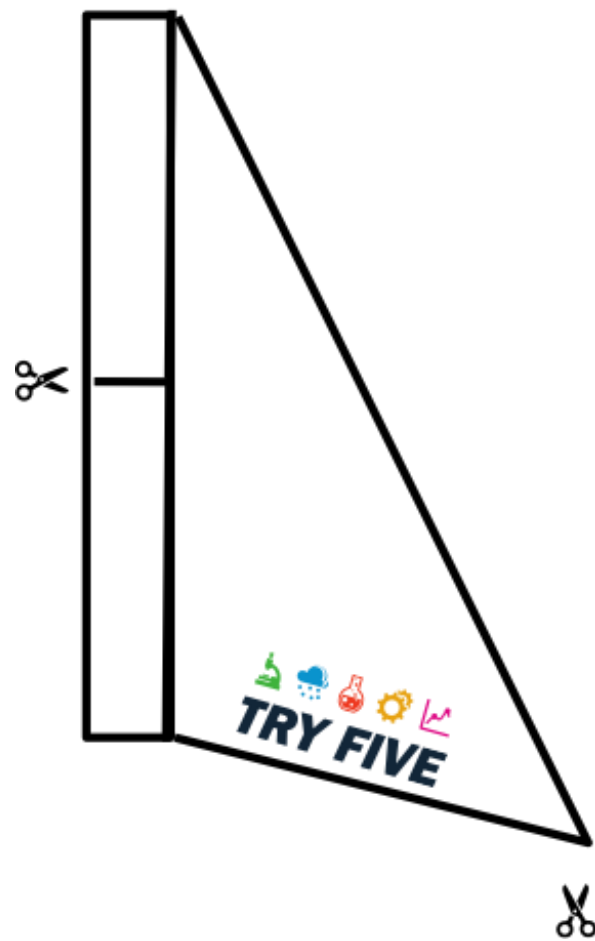

Design C

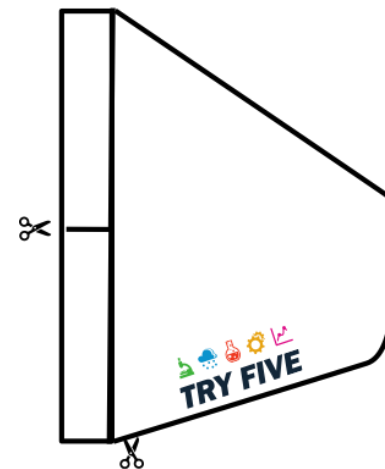

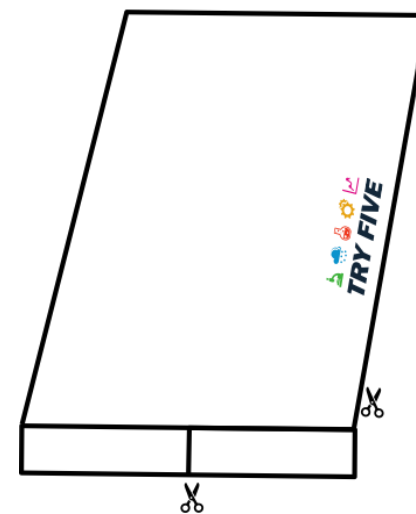

Design D

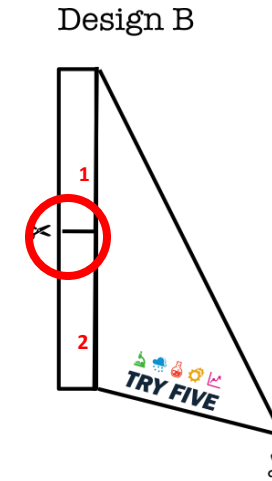
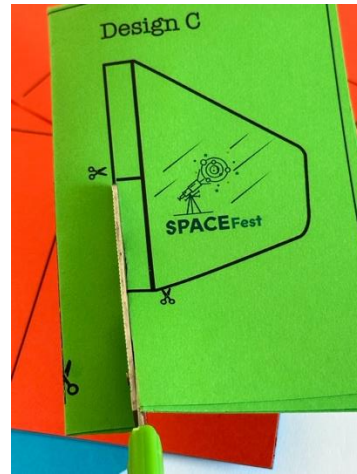
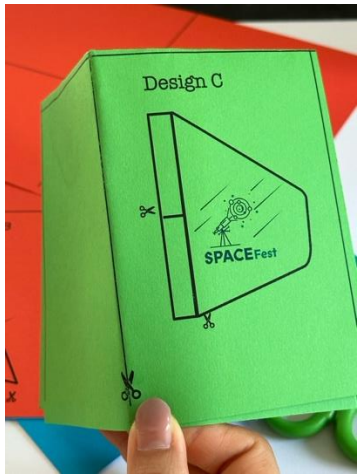



## Making the Fins

-  7. Pick your favorite fin shape. **Fold the paper twice!** Then cut along the outer curve. You'll get 4 exactly the same fins.
-  8. Hold the 4 fins together, cut along the short line but don't cut it through.
-  9. Fold piece 1 forward and piece 2 backward. Apply tapes on these pieces and attach the fins to the bottom of the body part.

# Making the Fins

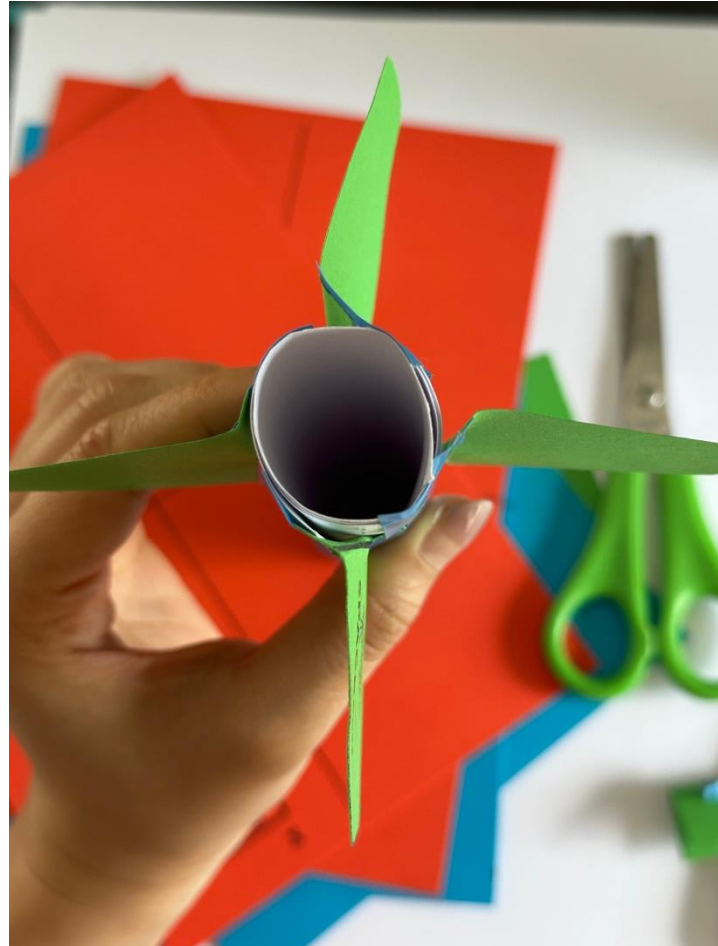

Tip 1: It's easier to put the tapes first, then attach it to the body part.

Tips 2: Make sure the distance of the fins are even. For example, if you want 4 fins, you can put them as 12 o'clock, 3 o'clock, 6 o'clock and 9 o'clock.

Tip 3: Try your best to make the fins at the same height.



QUALITY CHECKS!

# Launching the rocket

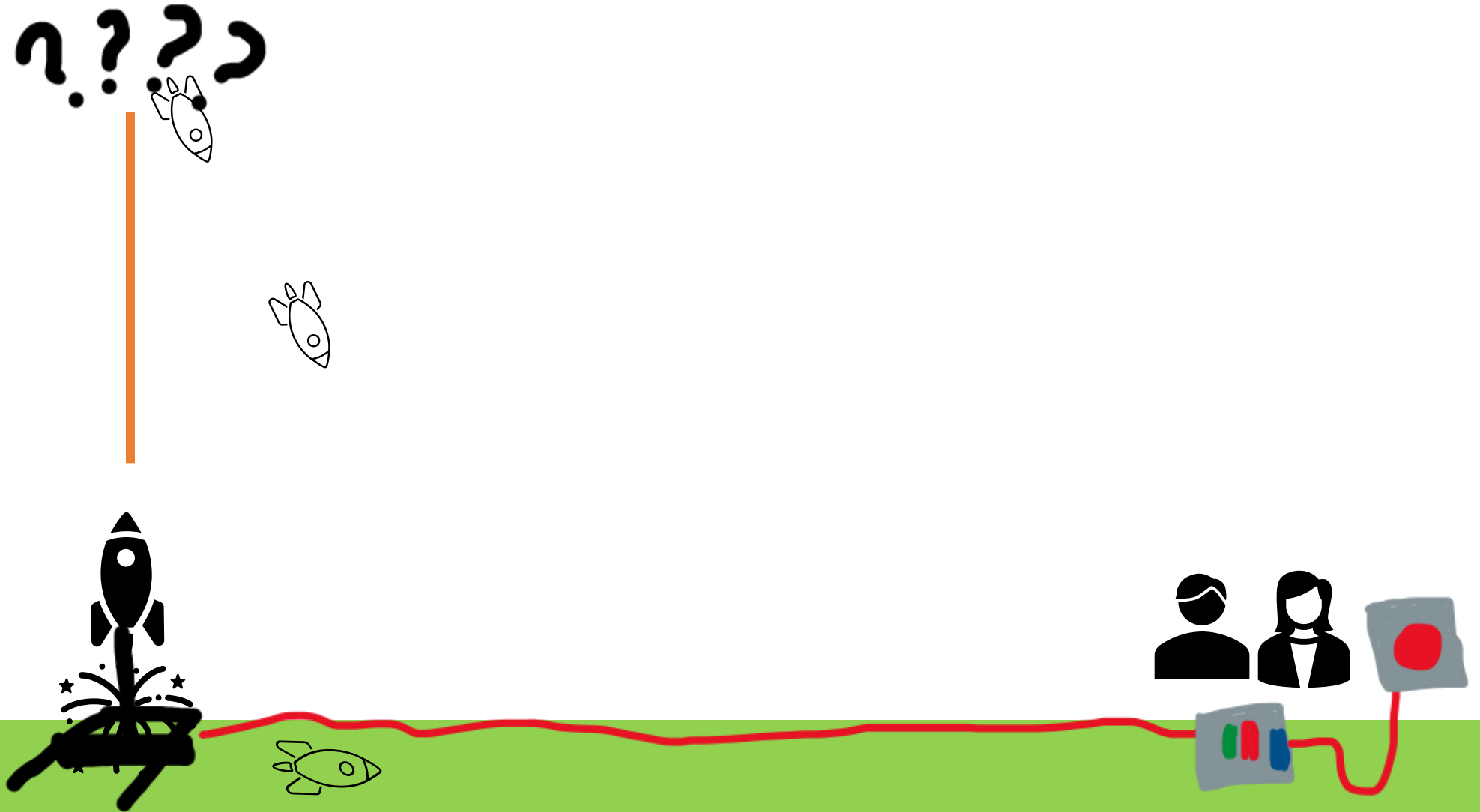



How high does my rocket go?

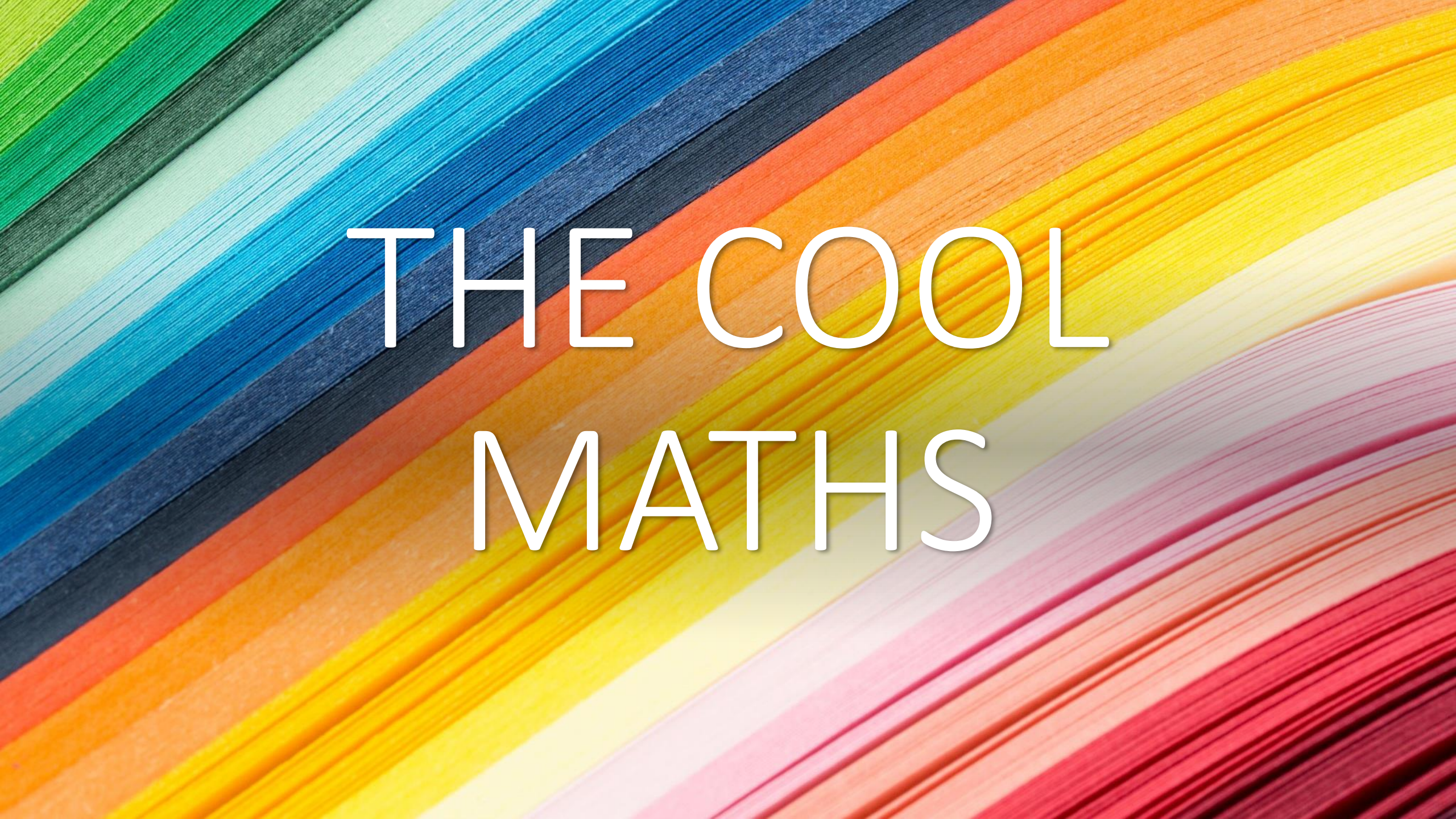

# THE COOL MATHS

# Knowing our angles

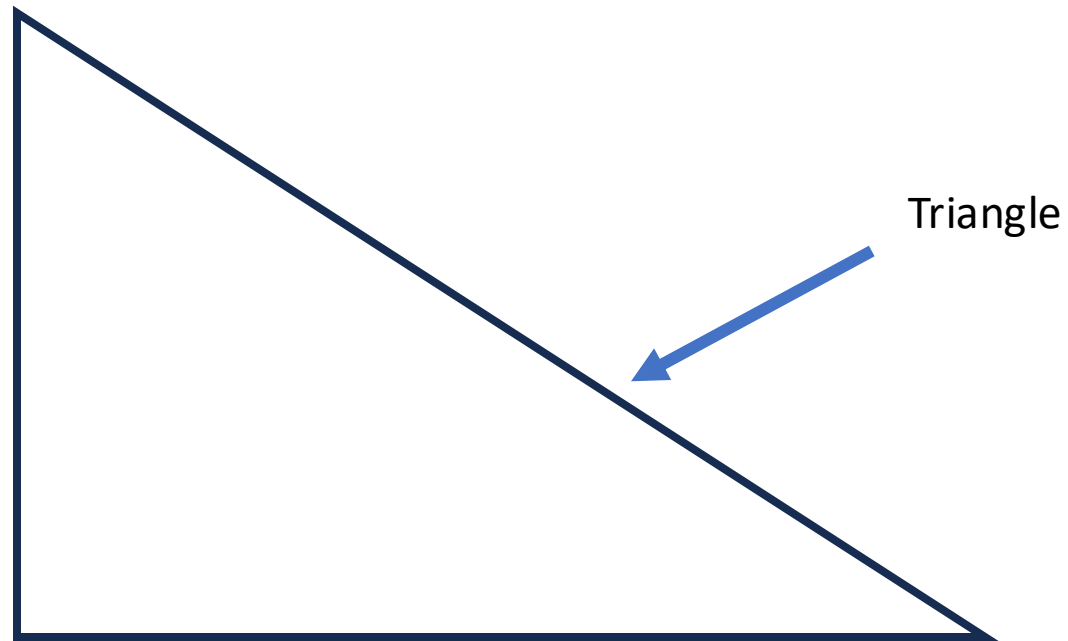

Do you know the name of this triangle in Maths?

# Knowing our angles

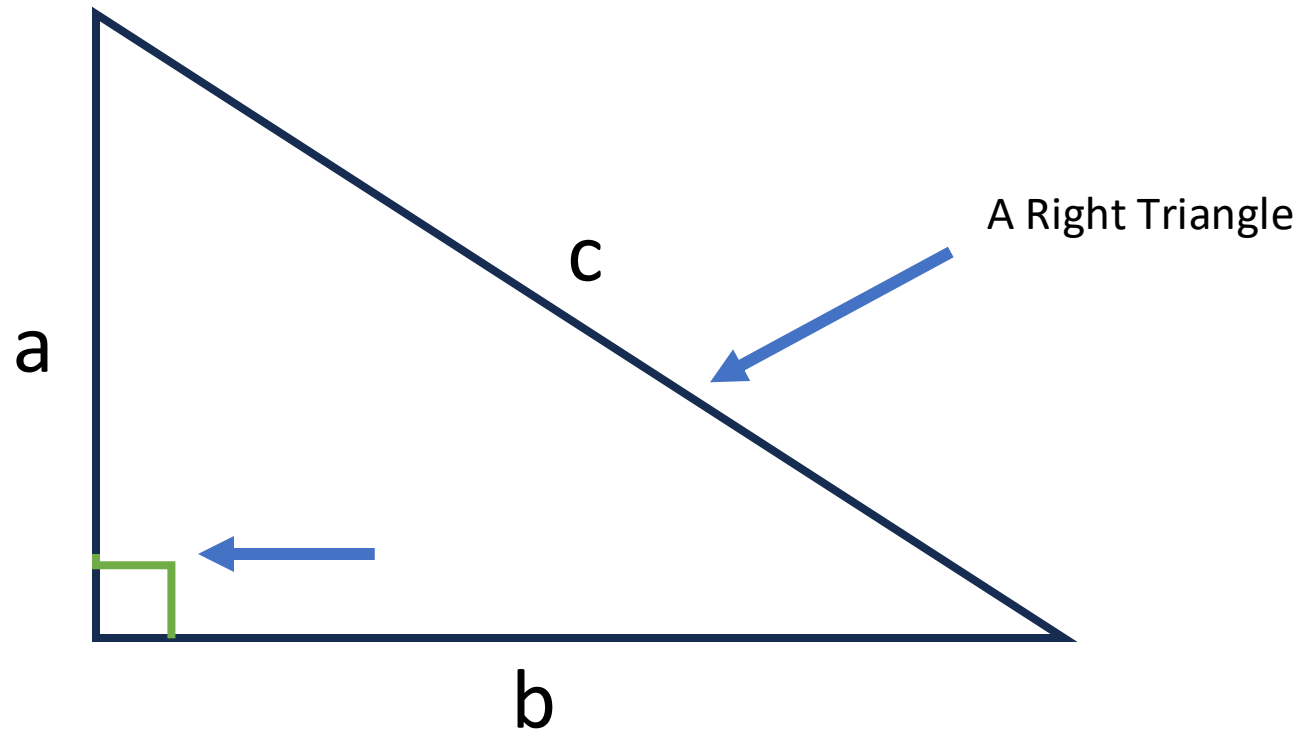

# Launching the rocket

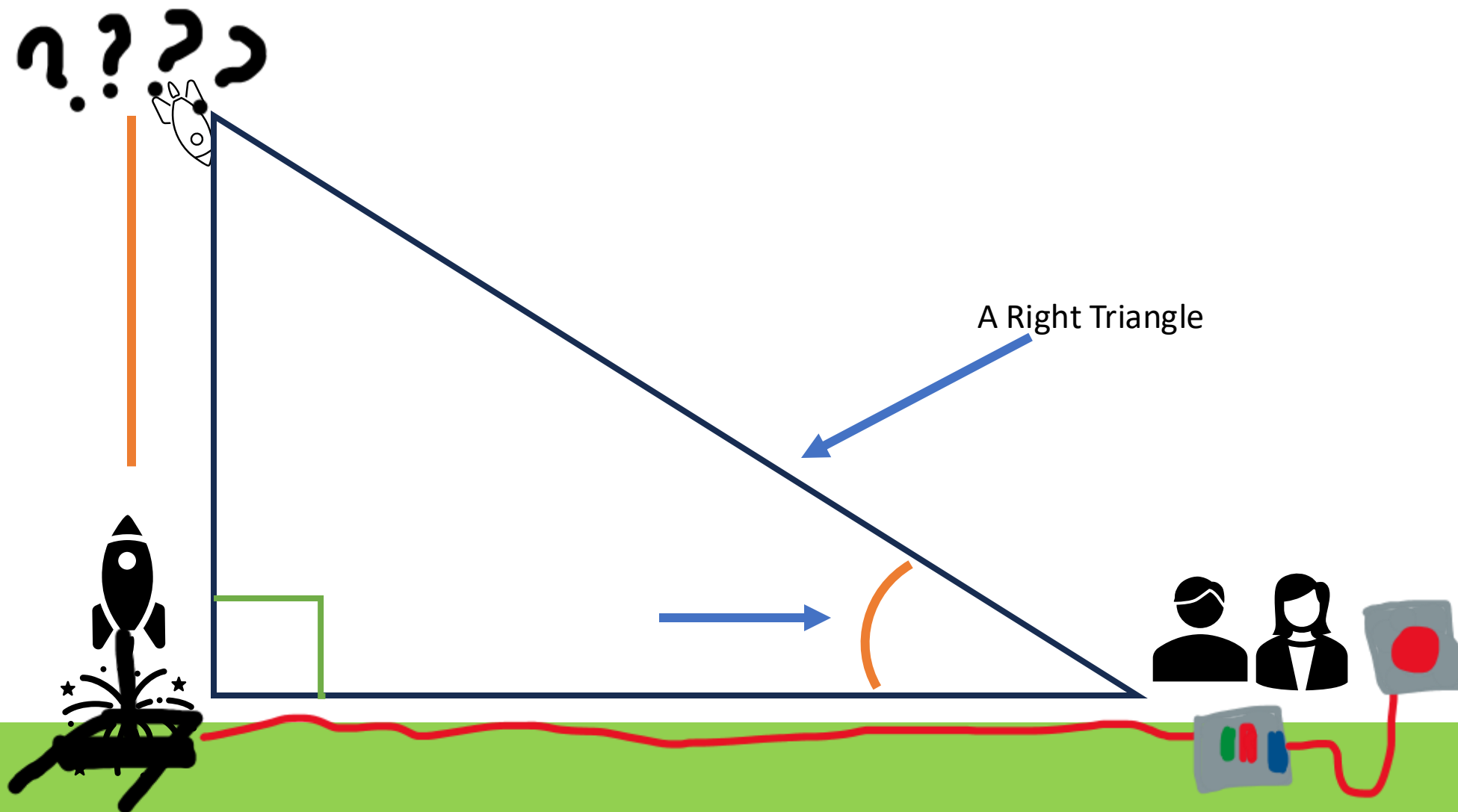

What do I know?

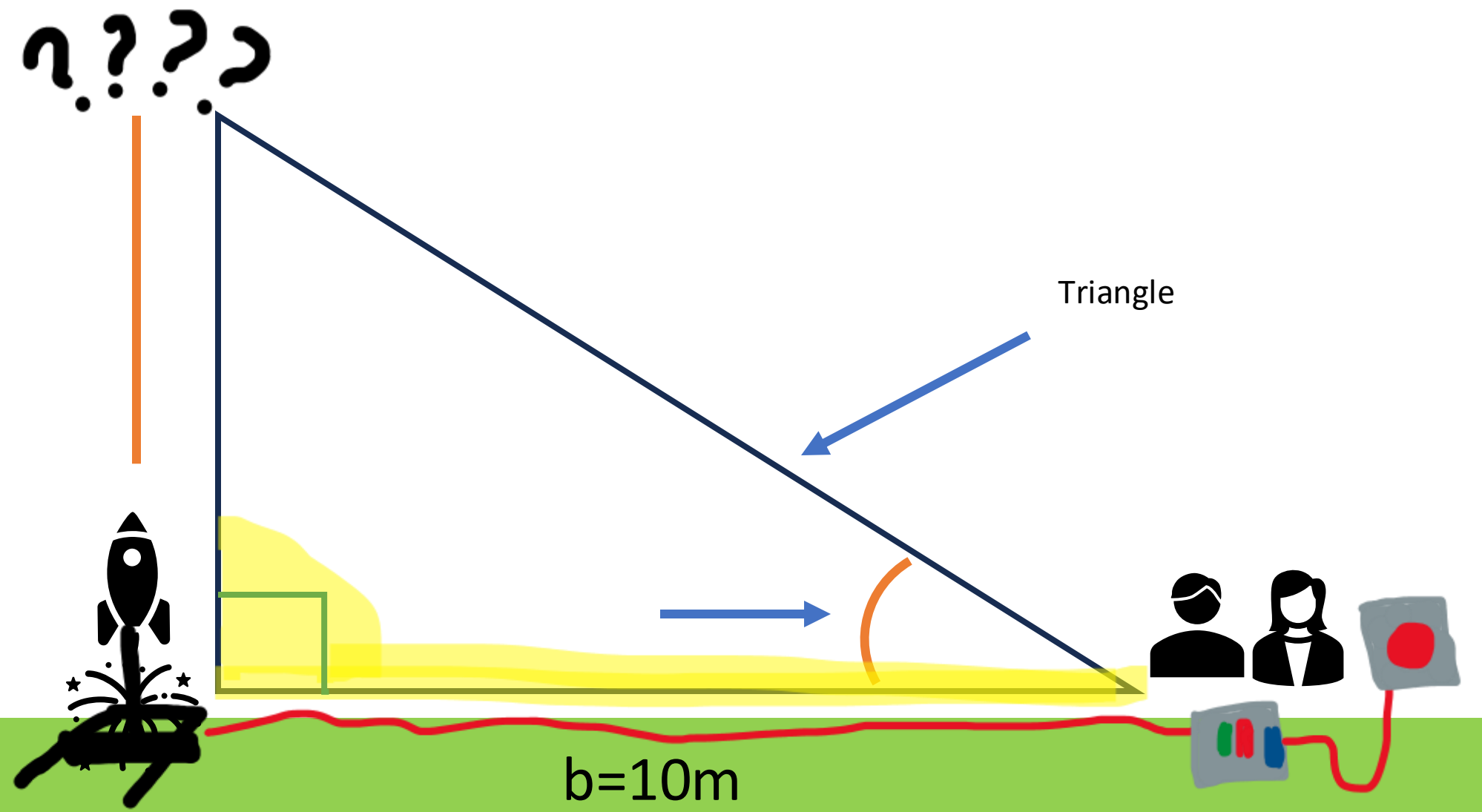

# What do I need to know?

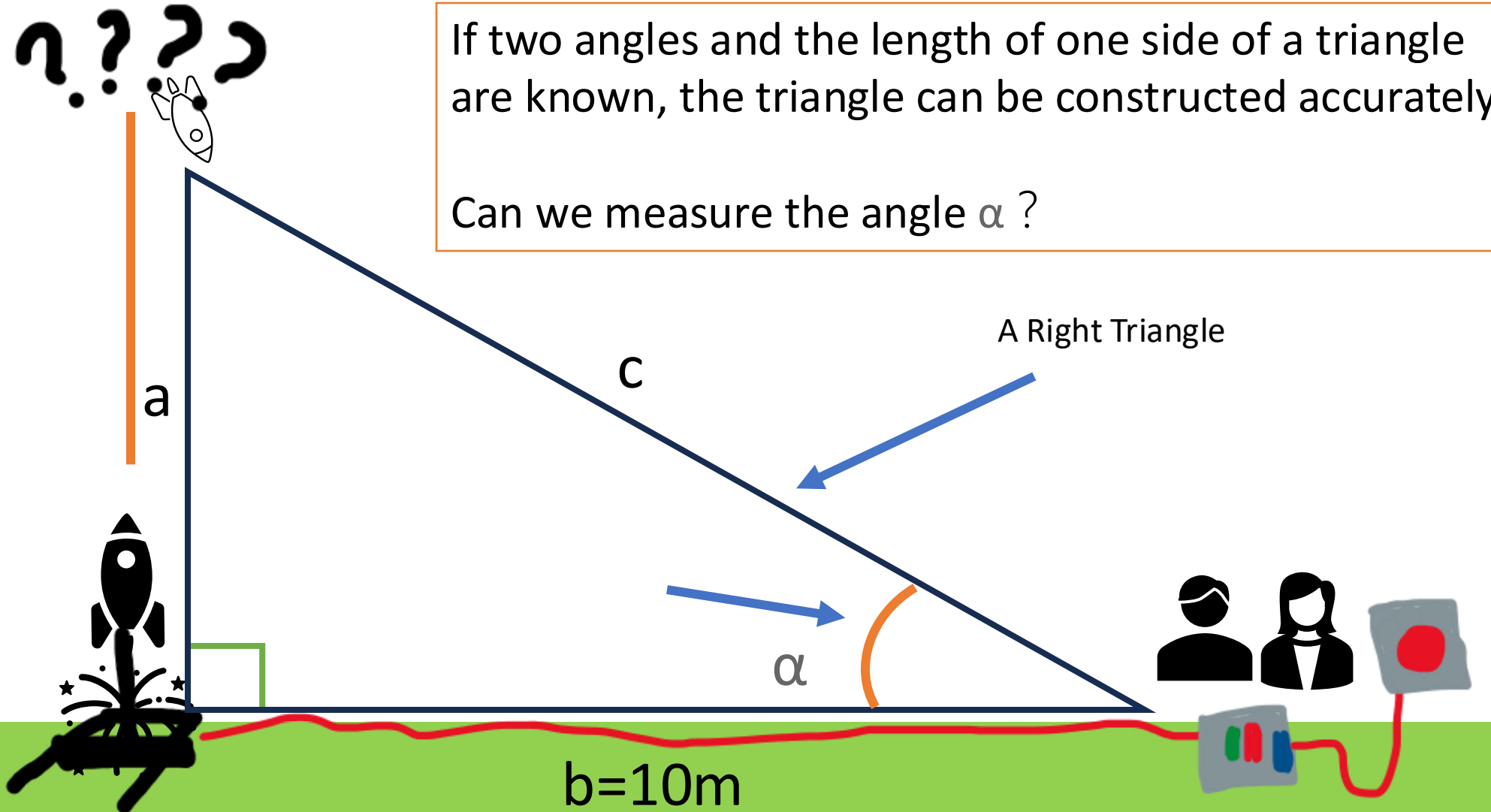

# How do we measure angles?

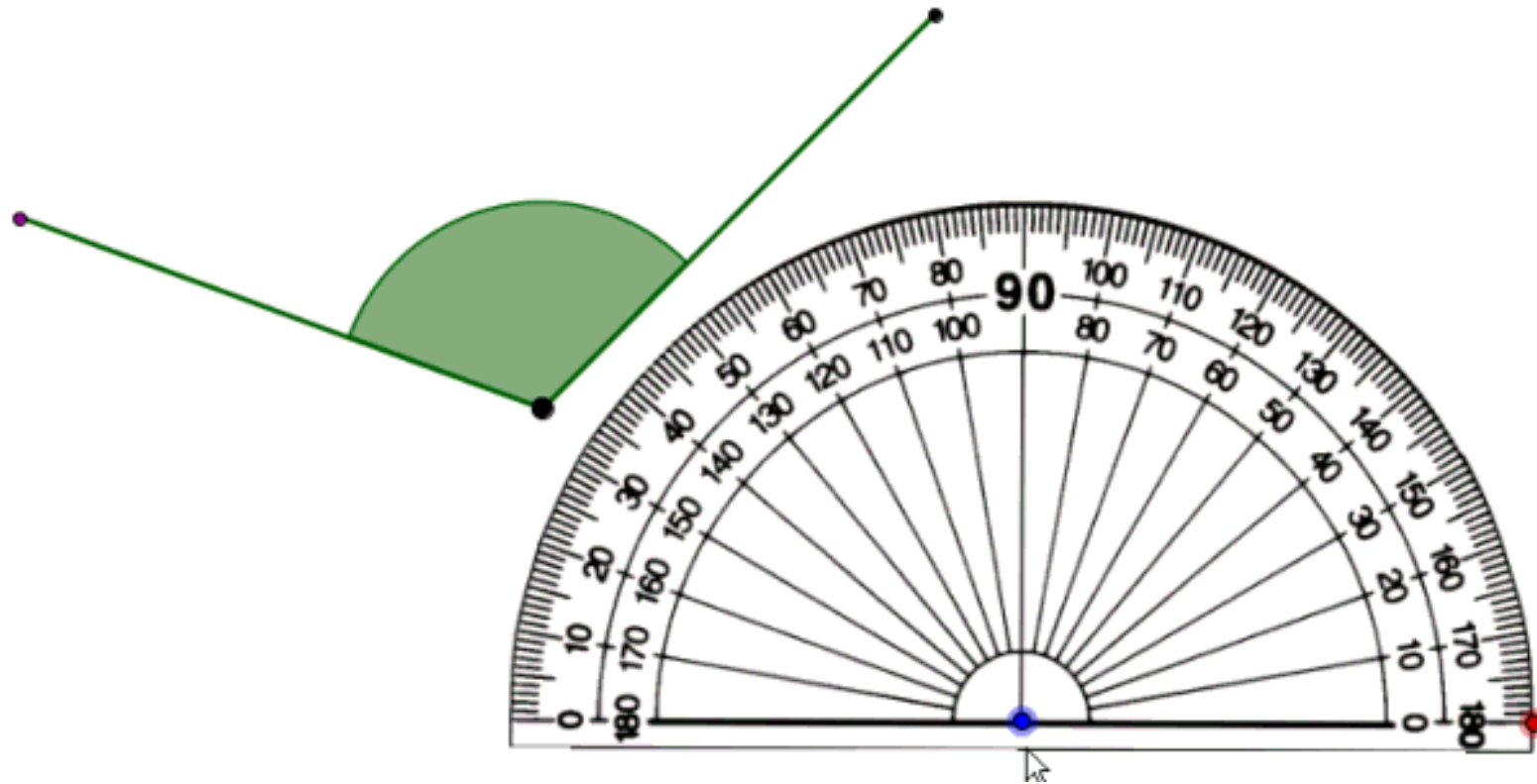



Let's try!

# Working at smaller scale!

Work in a group of 4:  
1 person launch the rocket  
1 person use the tool  
2 people read the angle

Then swap!



---

## 2. LAUNCHING THE ROCKET

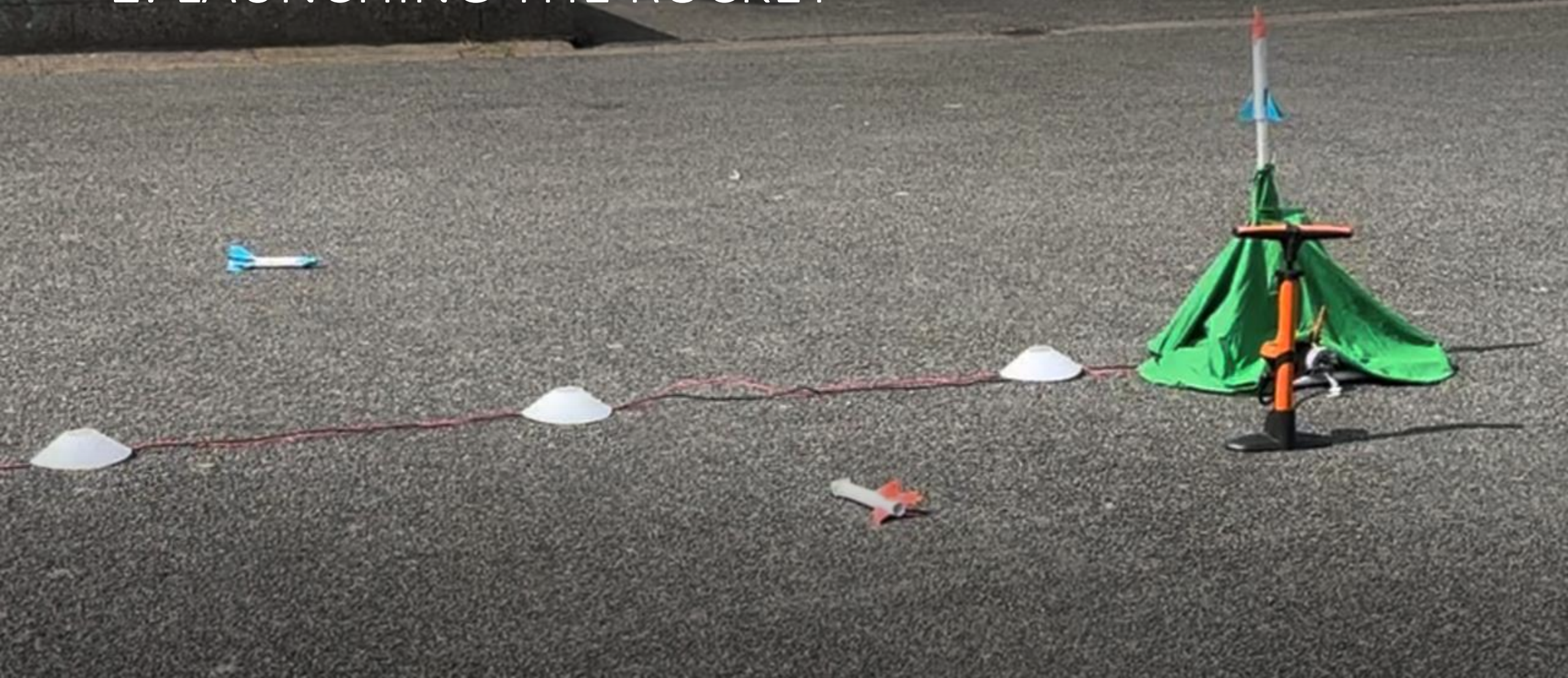



WM

131

# SAFETY RISKS

---

- Launcher failure
- Pressurized air
- Getting hit by a rocket
- Manual handling



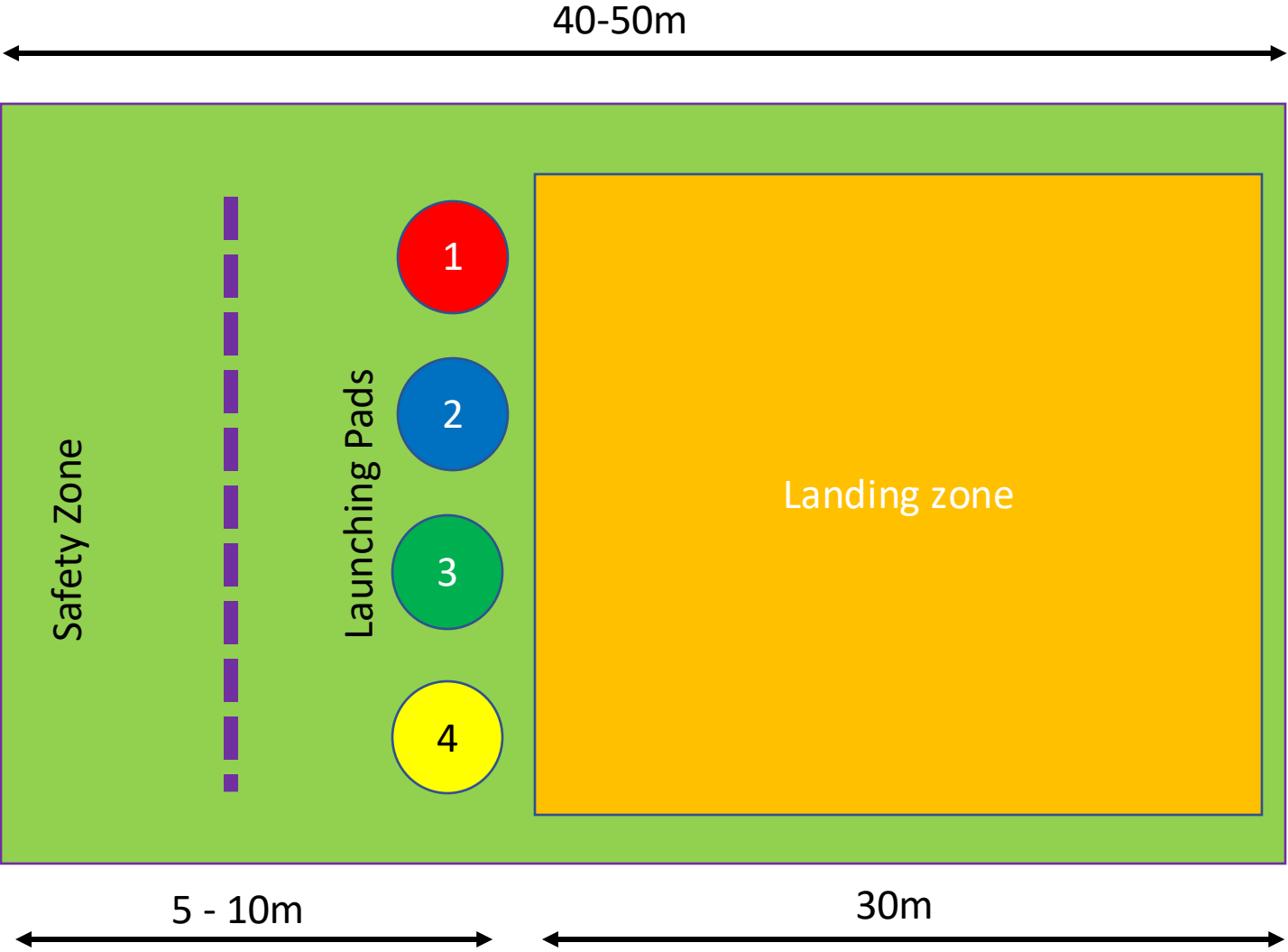

# ROCKET LAUNCHER

---

1. Load the rocket launcher.
2. Teacher will pump up to 2 bars.
3. Safety check. Activate arming buttons:
  - A) Rocket is in. Protective fabric is still in place.
  - B) Pressure not more than 2 bars.
  - C) Students behind the safety line. No bystanders/people near the launch and landing areas.
4. Give signal to launch. Let's count down together!
5. LAUNCH!
6. After all launchers have discharged → restart

Thank you

---

