



T DUBLIN
TECHNOLOGICAL UNIVERSITY DUBLIN
OLLSCOIL TEICNEOLAÍOCHTA BHÁILE ATHA CLIATH

TRY FIVE +

workday. | An Roinn Oideachais Department of Education | Taighde Éireann Research Ireland



MISSION 3

STARS AND ELECTRONICS





ASTRONOMY

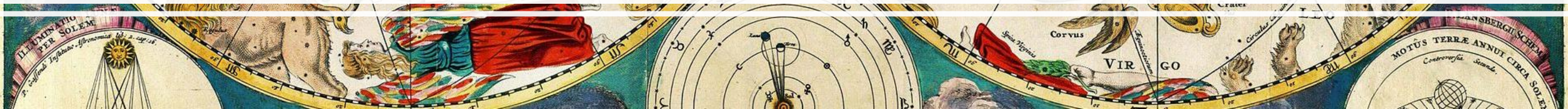

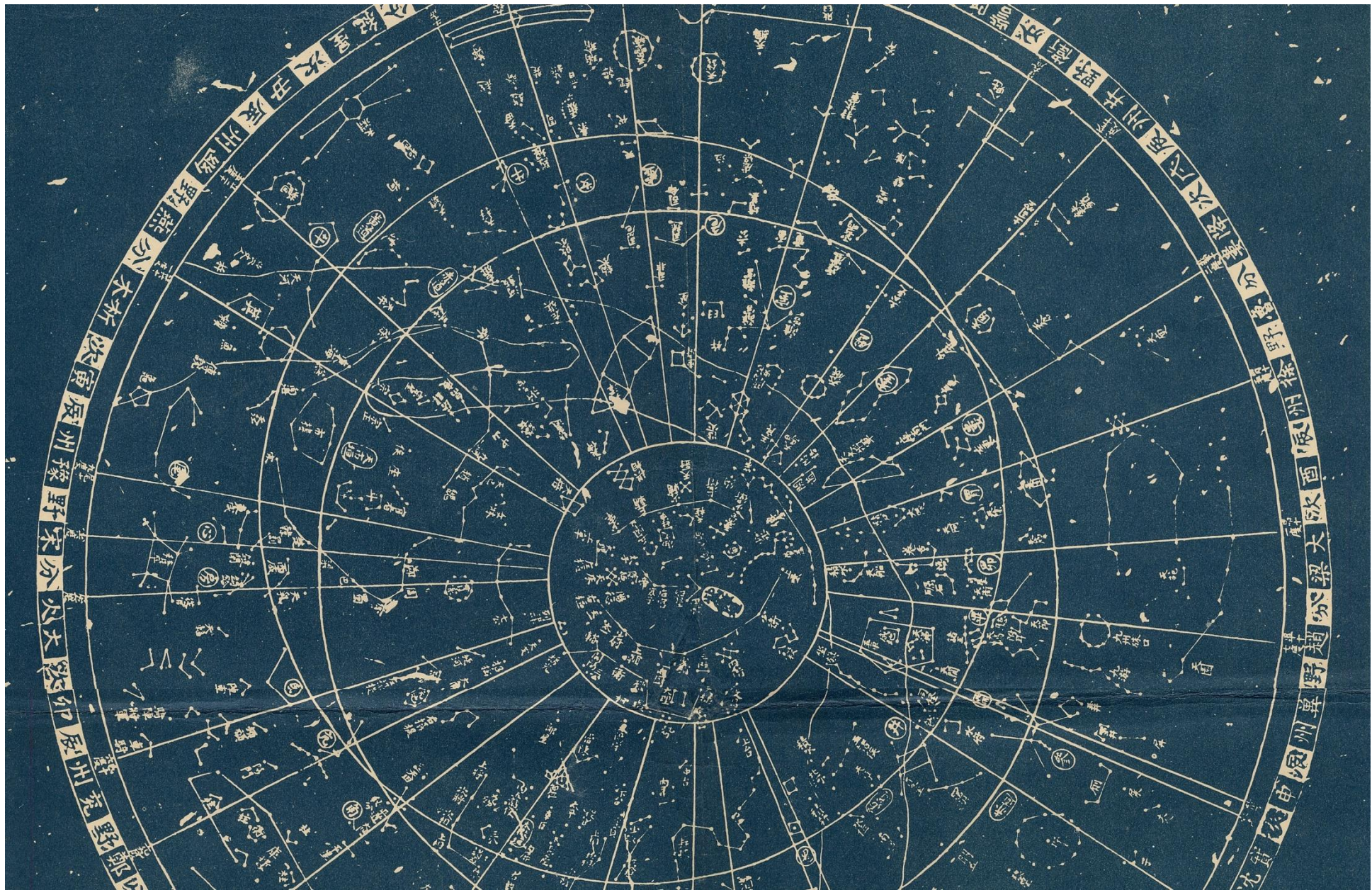

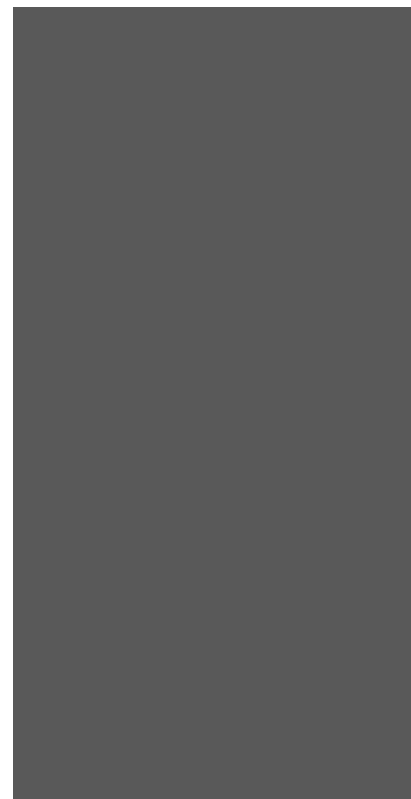
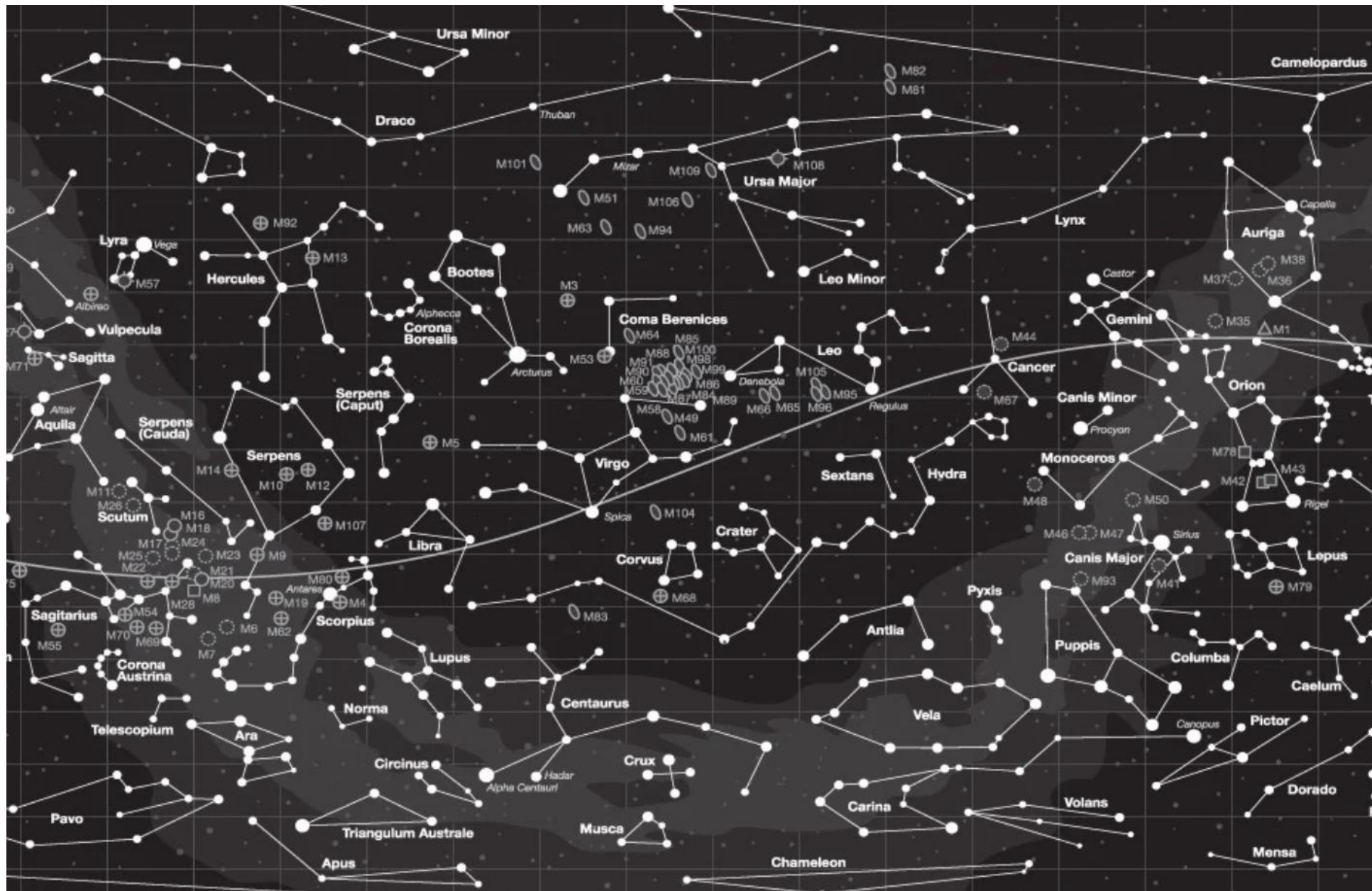

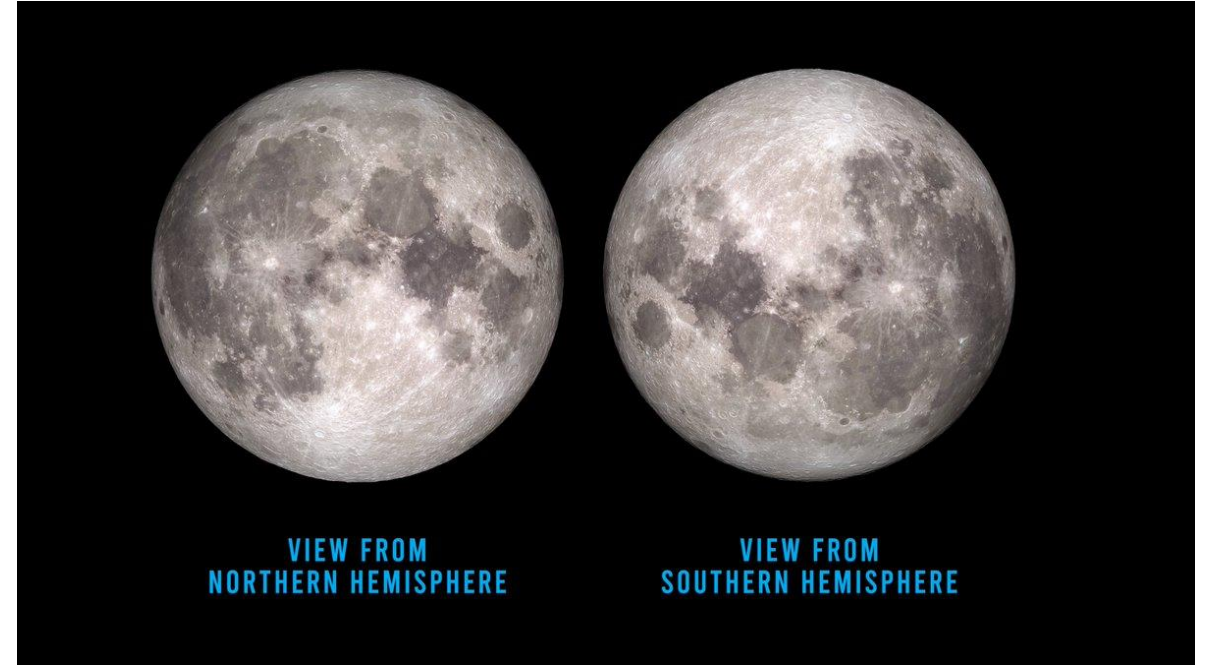
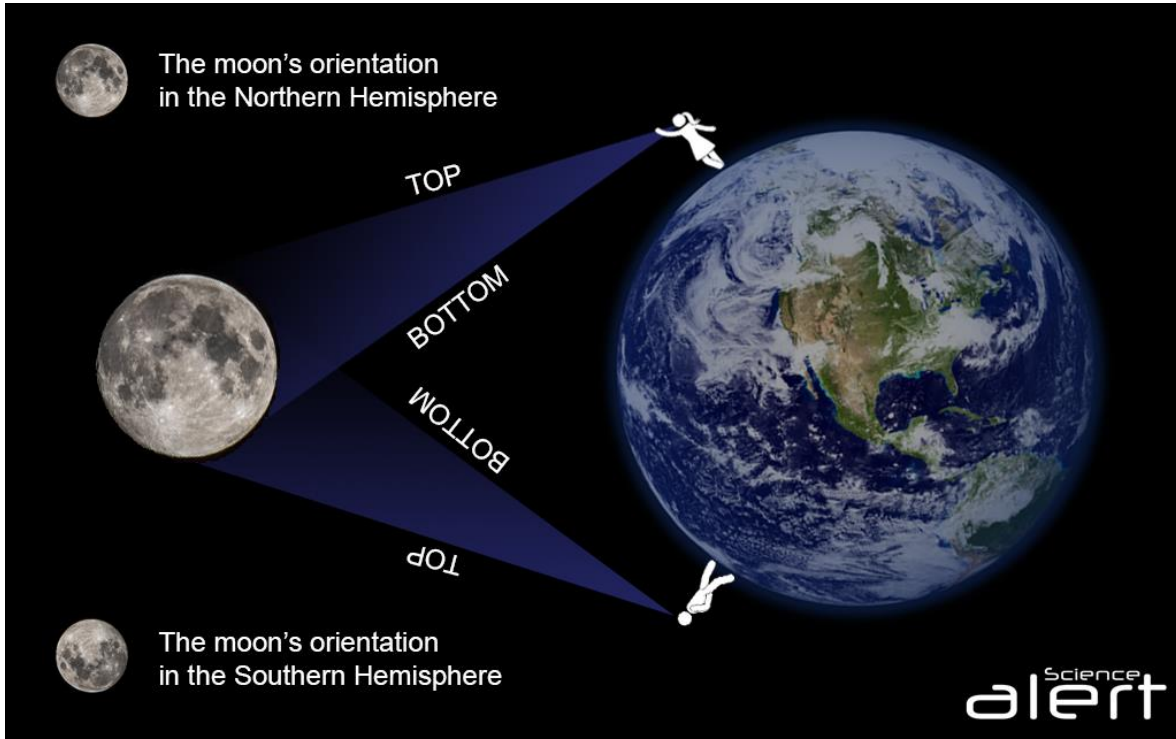

Views of the moon



MAKING A STAR PROJECTOR



**SAFETY
FIRST**

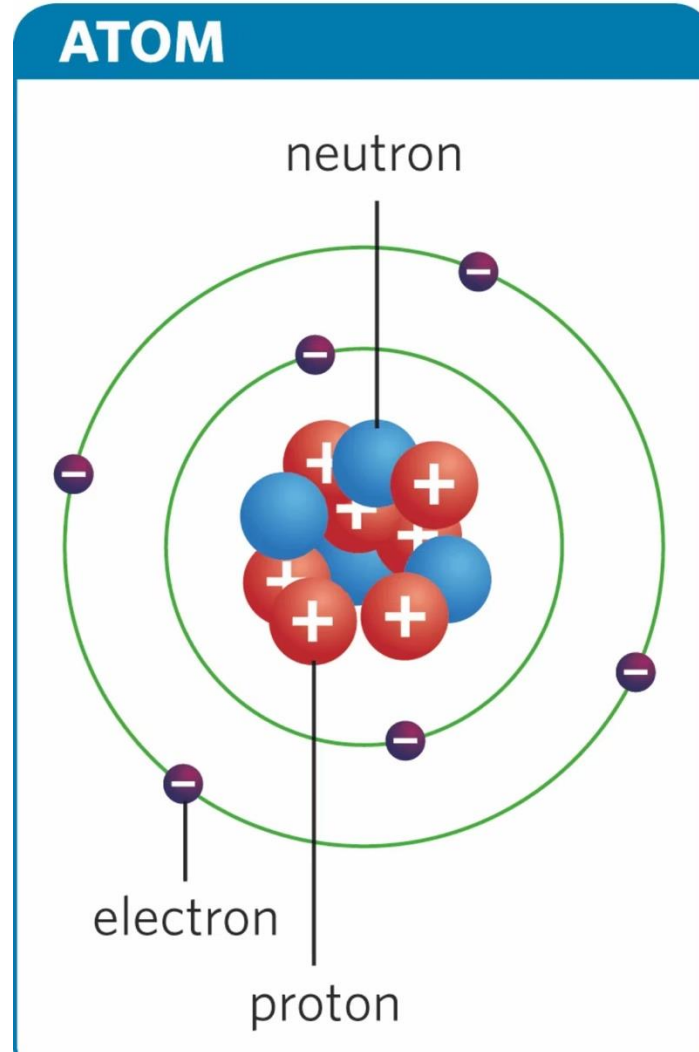

WHAT IS ELECTRIC ENERGY?

- **Electricity** is produced by **the flow of electric charge**.
- Electricity is made when tiny pieces called **electrons** move around. This movement gives us power. The movement of electrons is what forms an **electric current**.
- We can send this power **through wires** to make things work, like lights, heaters, and computers.

Game time!

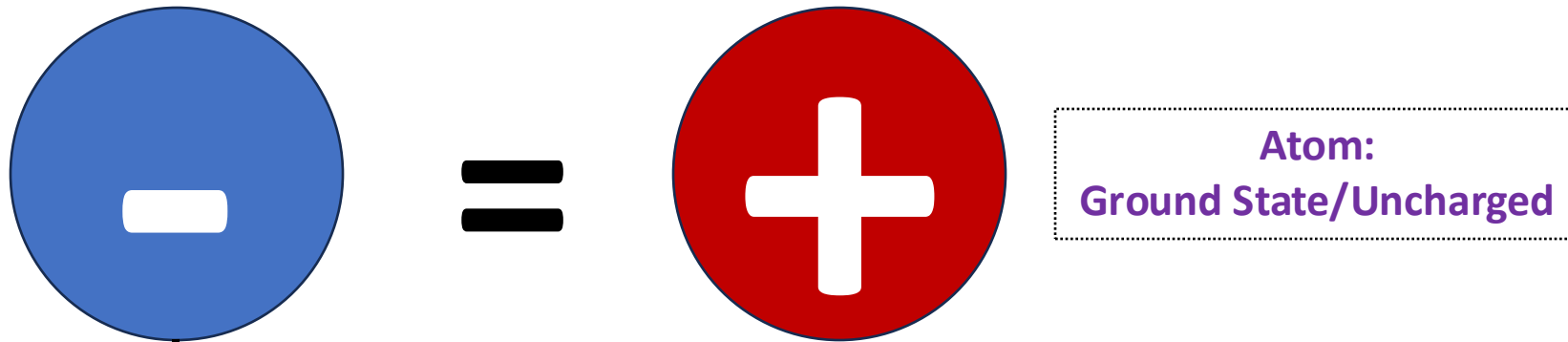

we can change the atom's **charge**, or energy level, by causing it to **gain** or **lose** electrons.

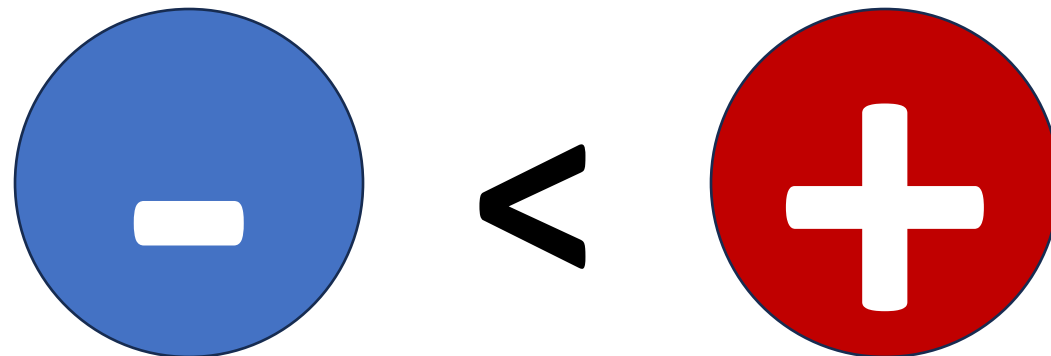
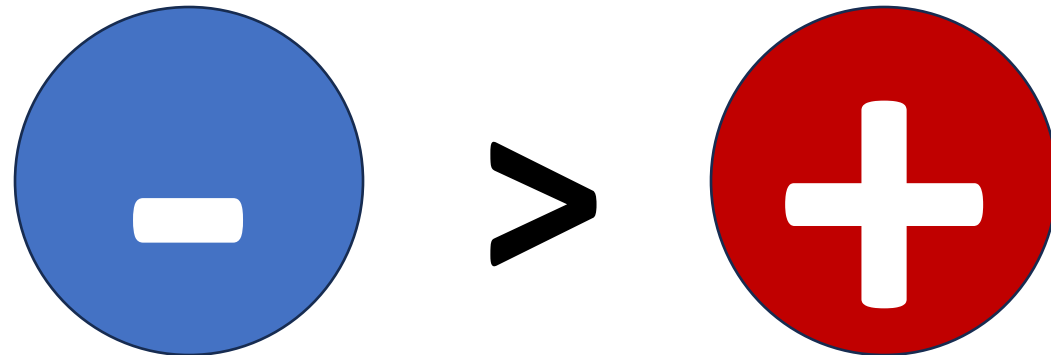

+1
+1
+1
...

-1
-1
-1
...

Experiment!

What will happen when these two groups meet?

Positive and negative charges are attracted

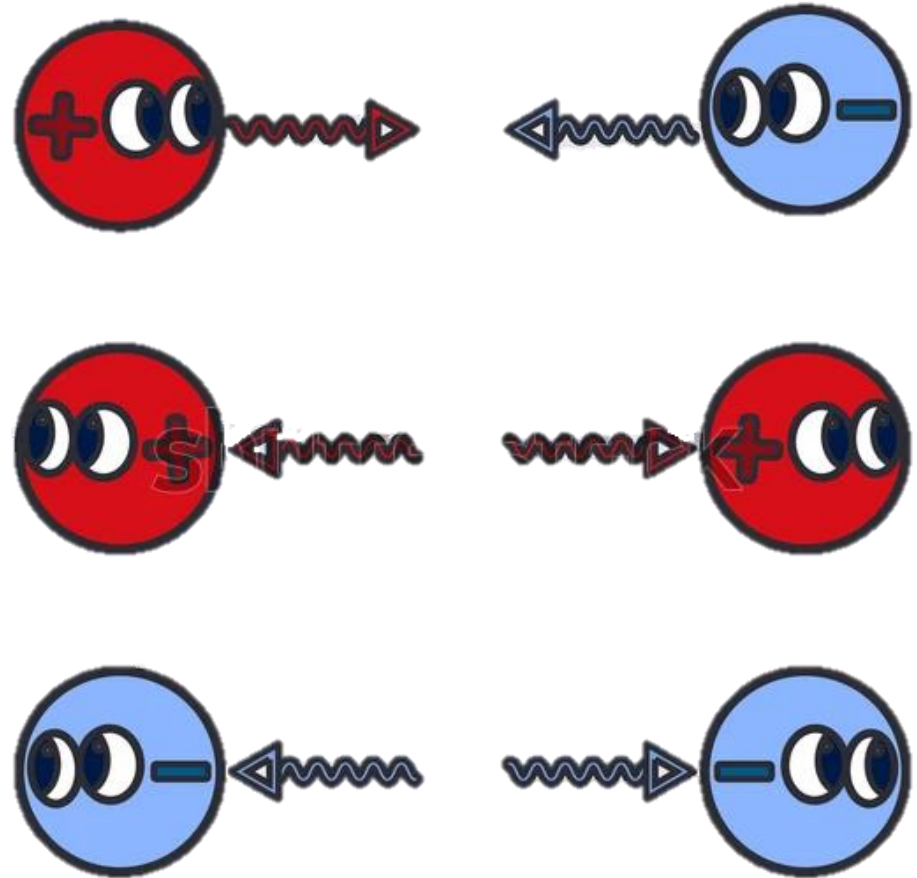

ELECTRIC POTENTIAL / POTENTIAL DIFFERENCE

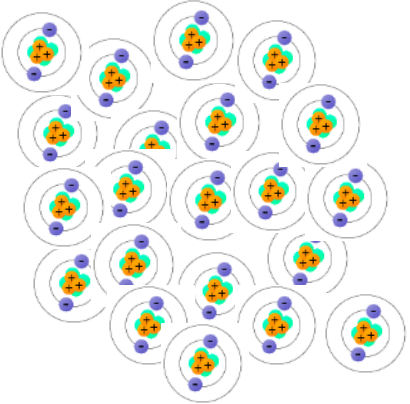
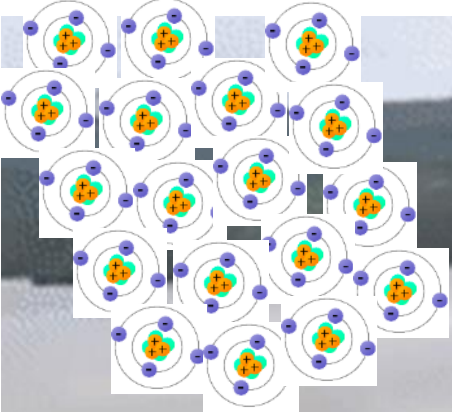

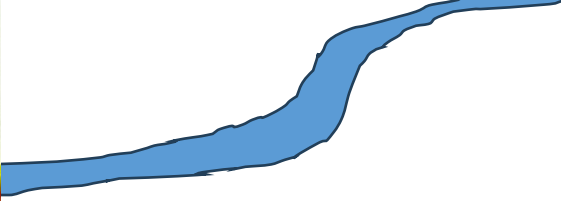
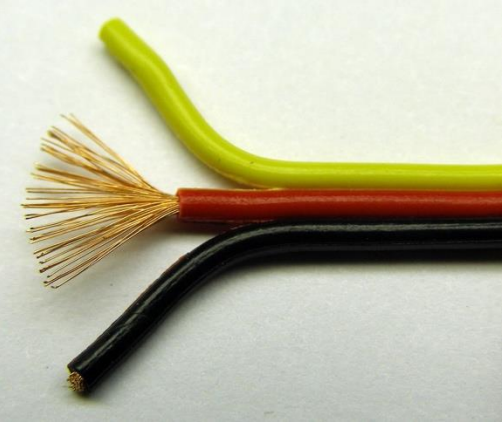

How do we use this potential?

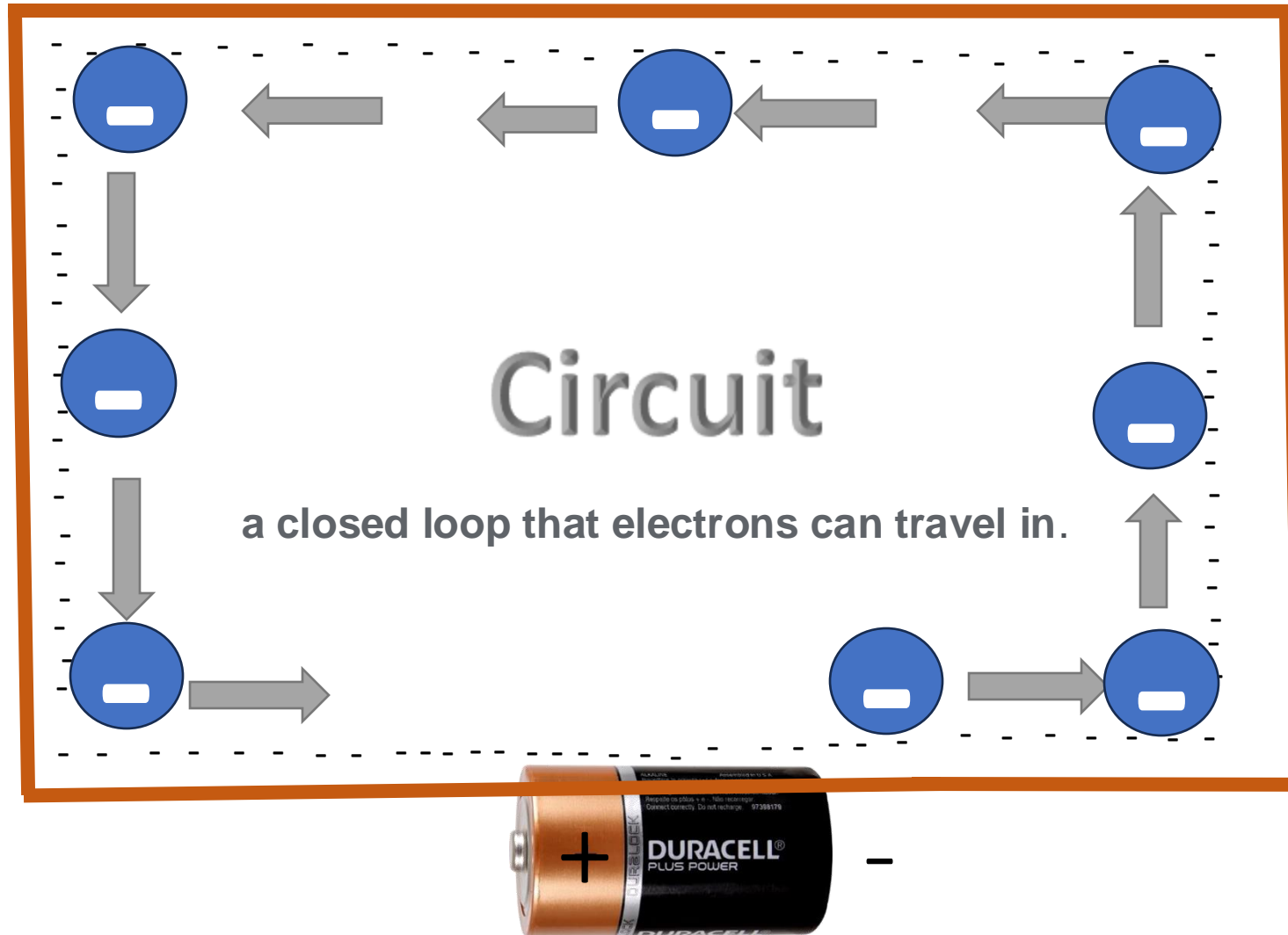



Human circuit

- Closed – Open

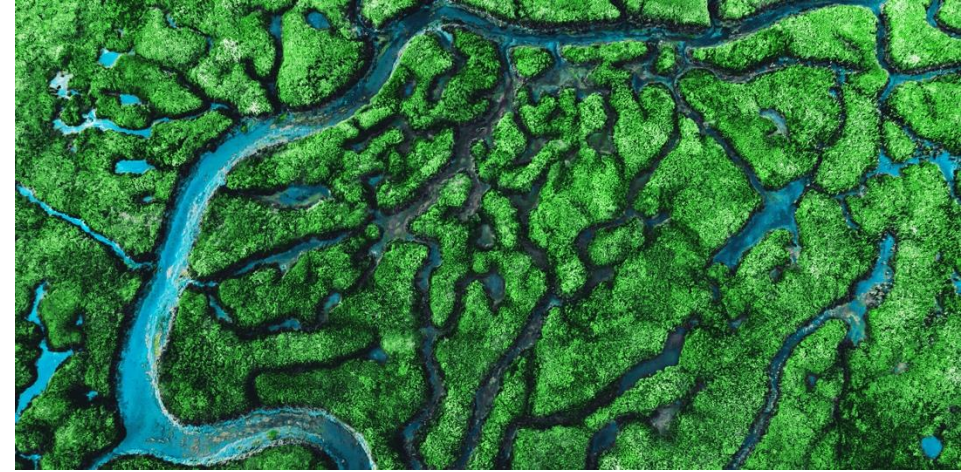
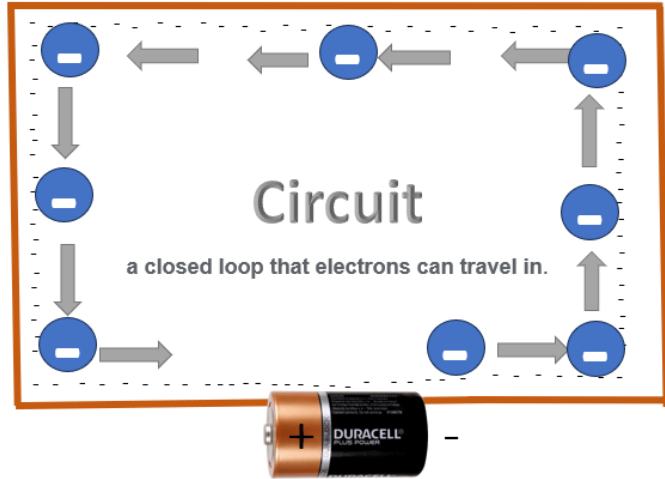

- **Current (Ampere):** How much electricity is flowing.
- **Voltage (Volt):** How fast the electricity is flowing.
- **Energy (Joule):** How much electricity is in total.
- **Power (Watt):** How much electricity flows in a certain amount of time. If voltage is the pressure, watt is the work done by that pressure over time.

Flow of electrons

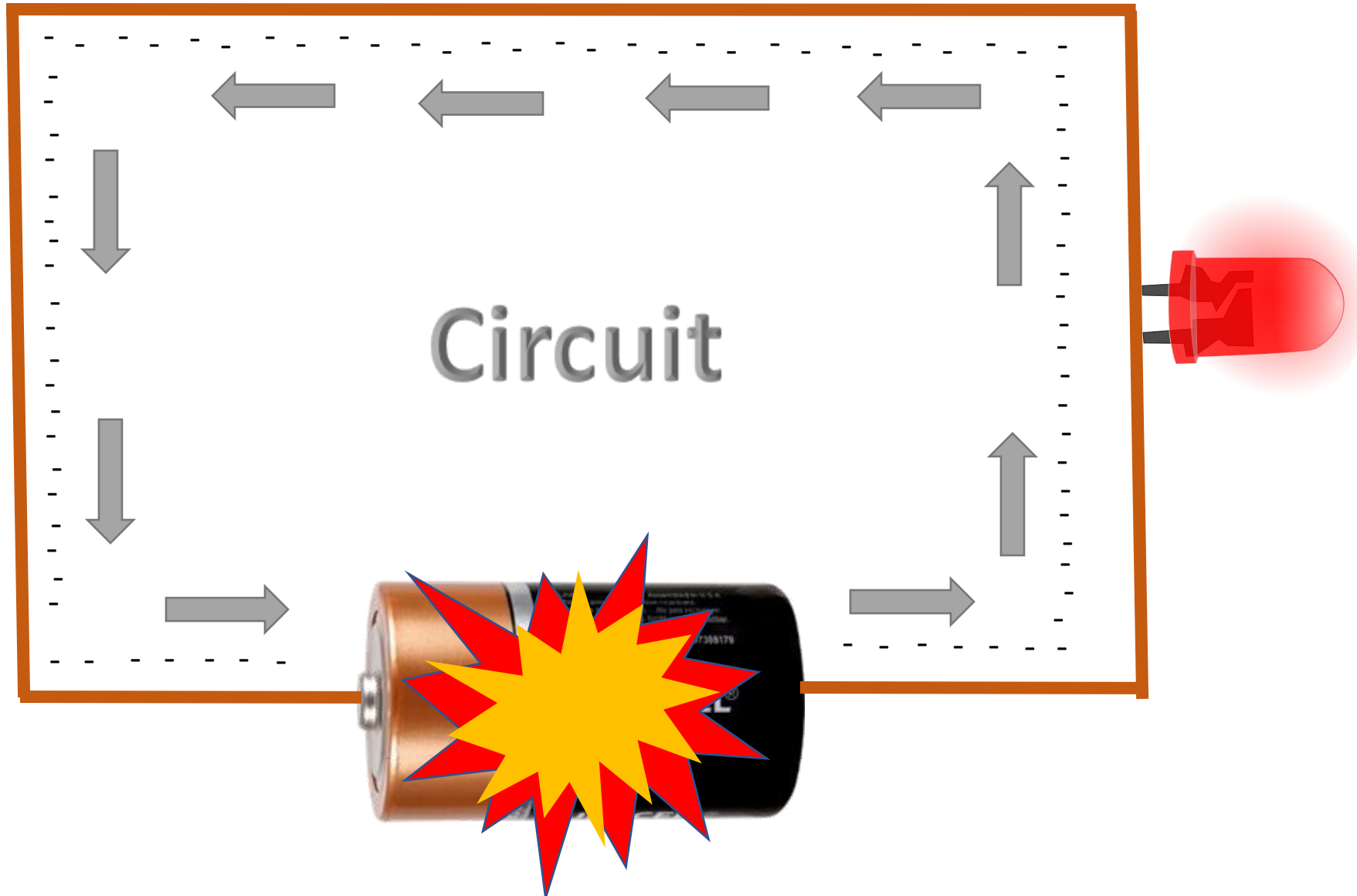

LET'S CREATE THE CIRCUIT?







INTERESTING

WHAT WENT WRONG?





The volts and the water wheel



LET'S TRY?

Batteries
in series

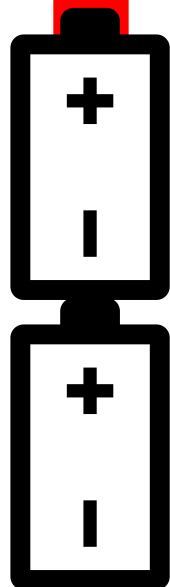

Voltage X2

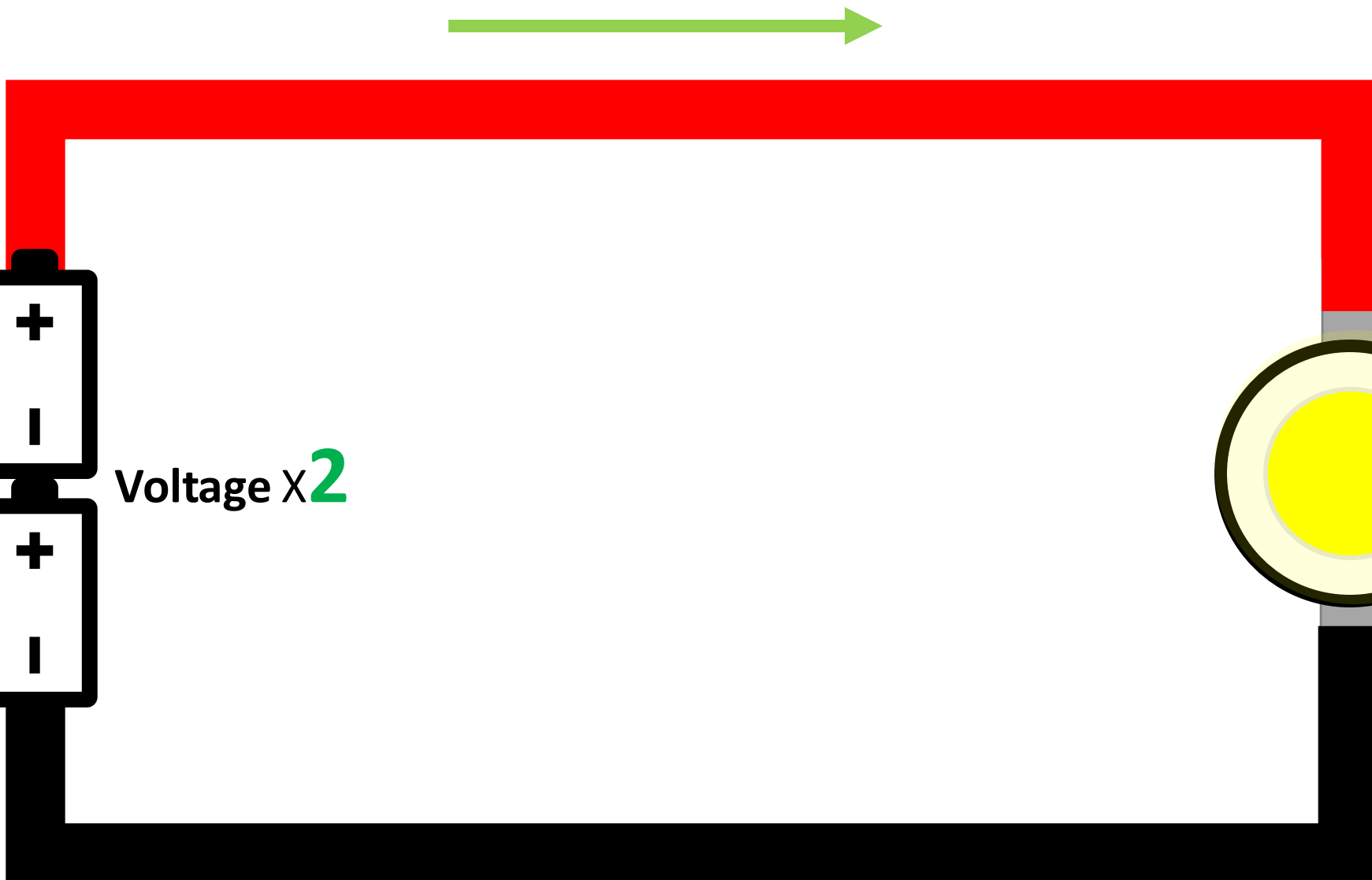

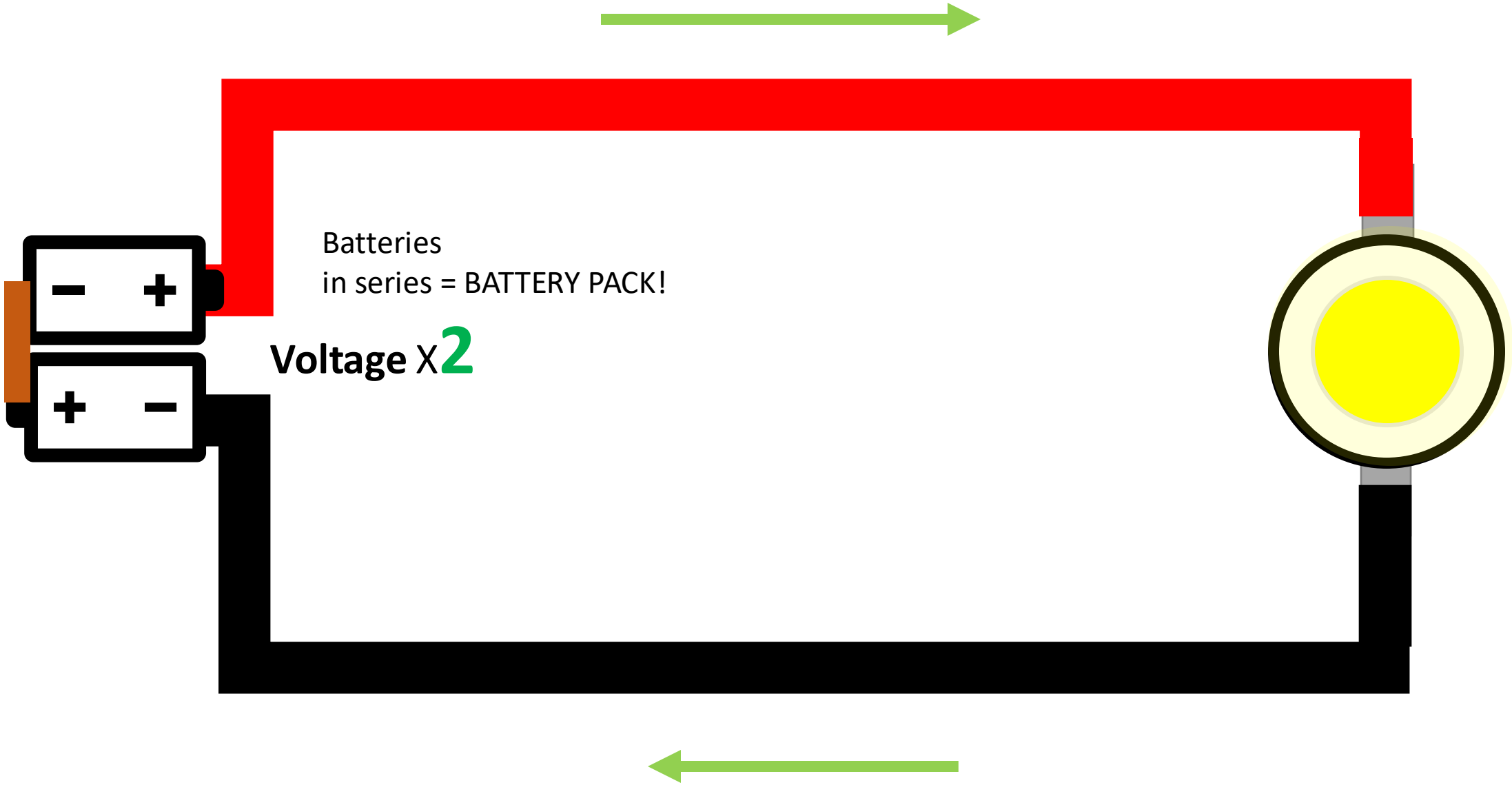

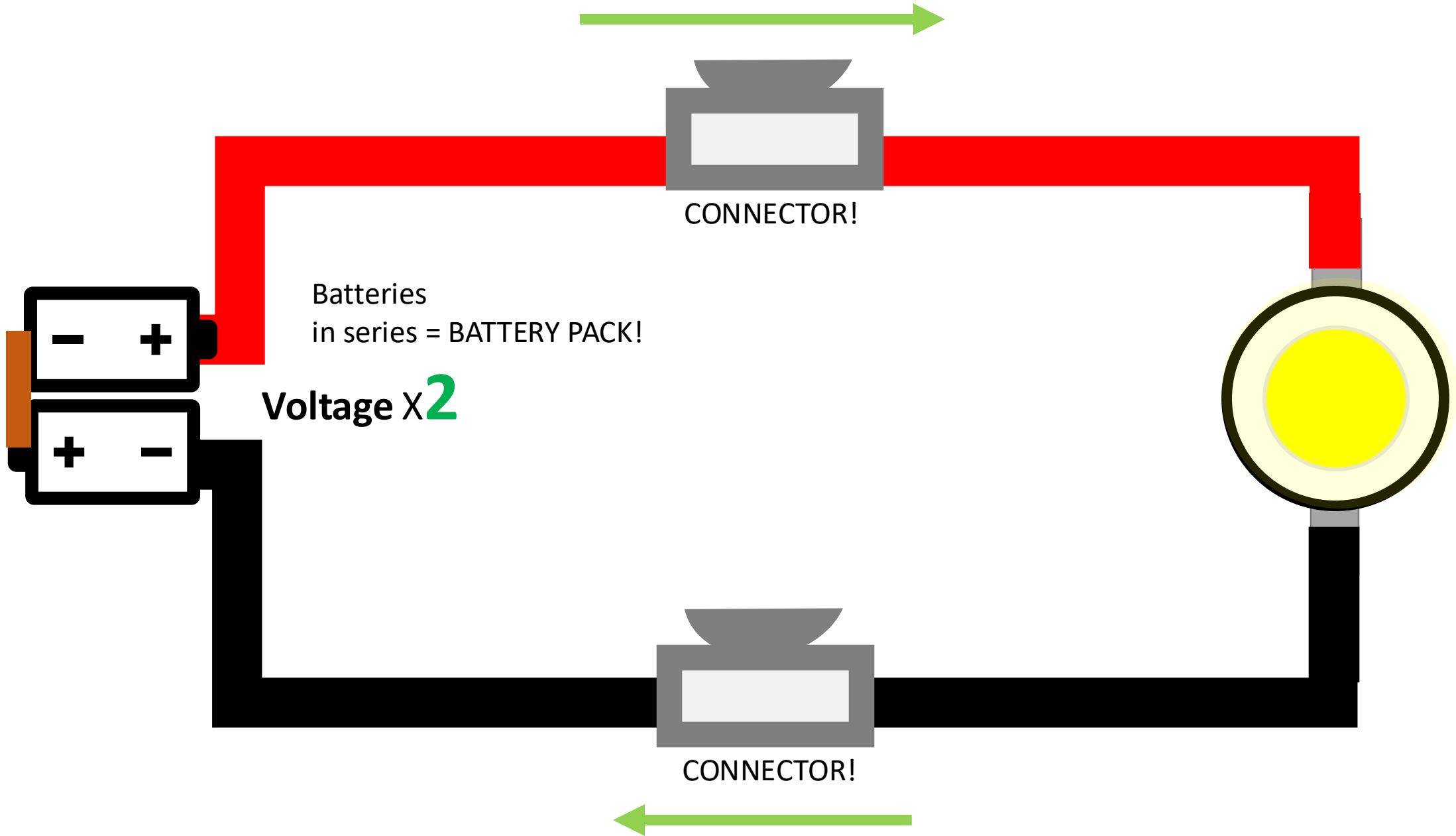

SPRING CONNECTORS

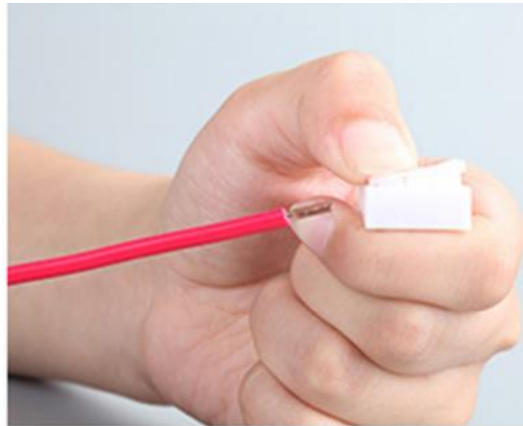
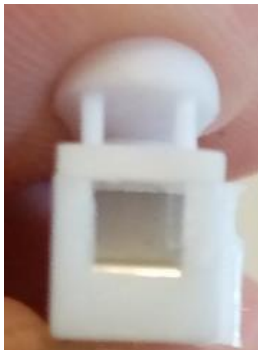
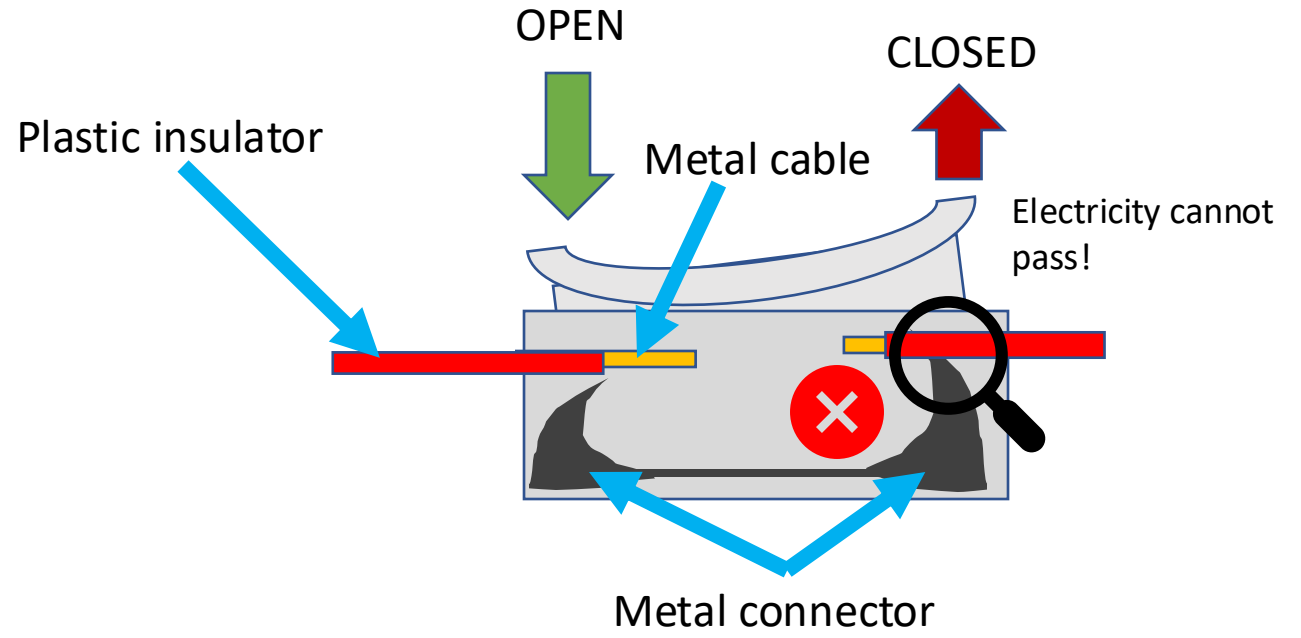
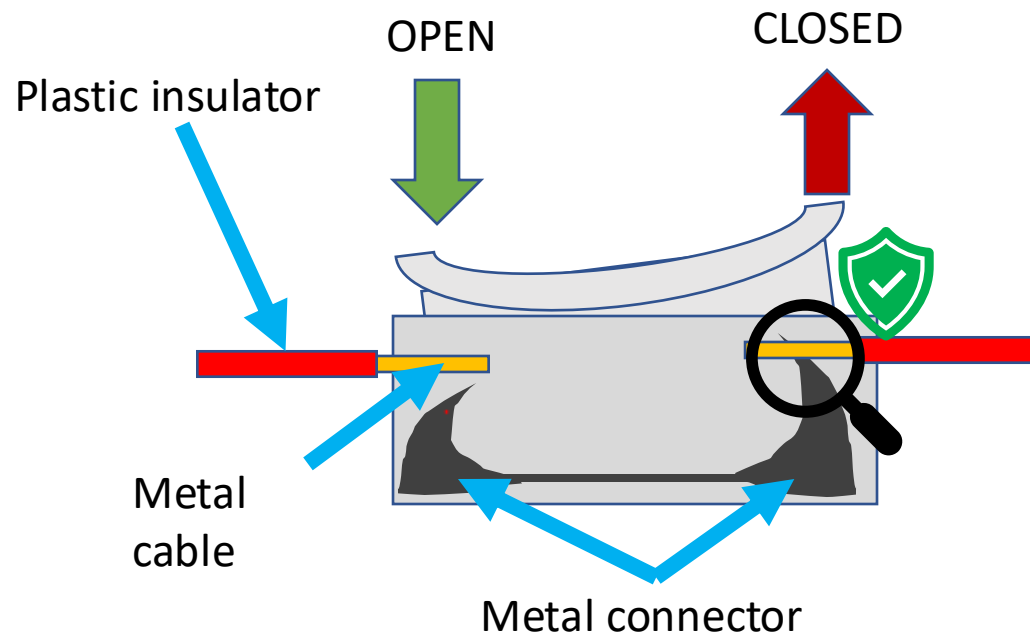

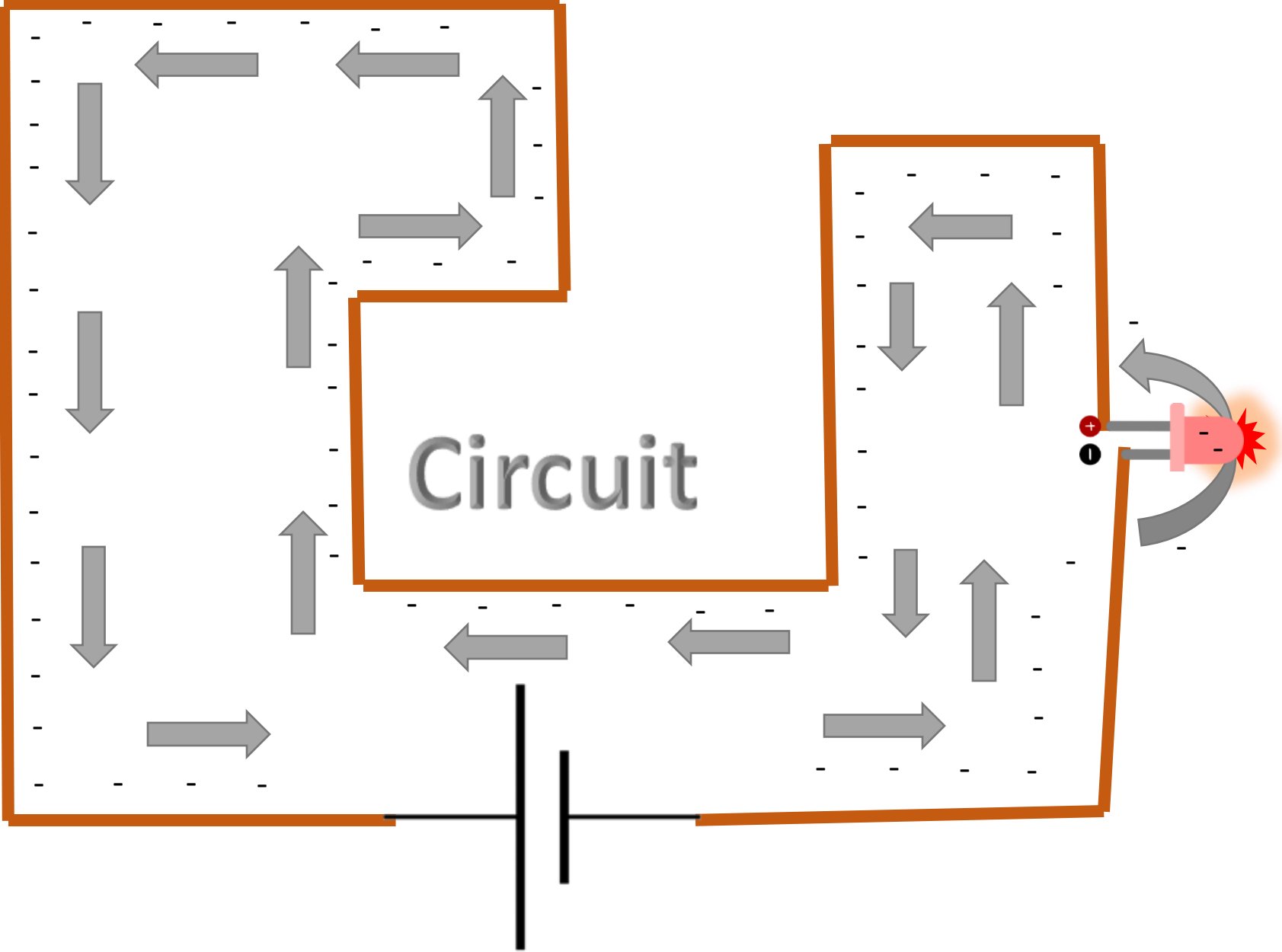

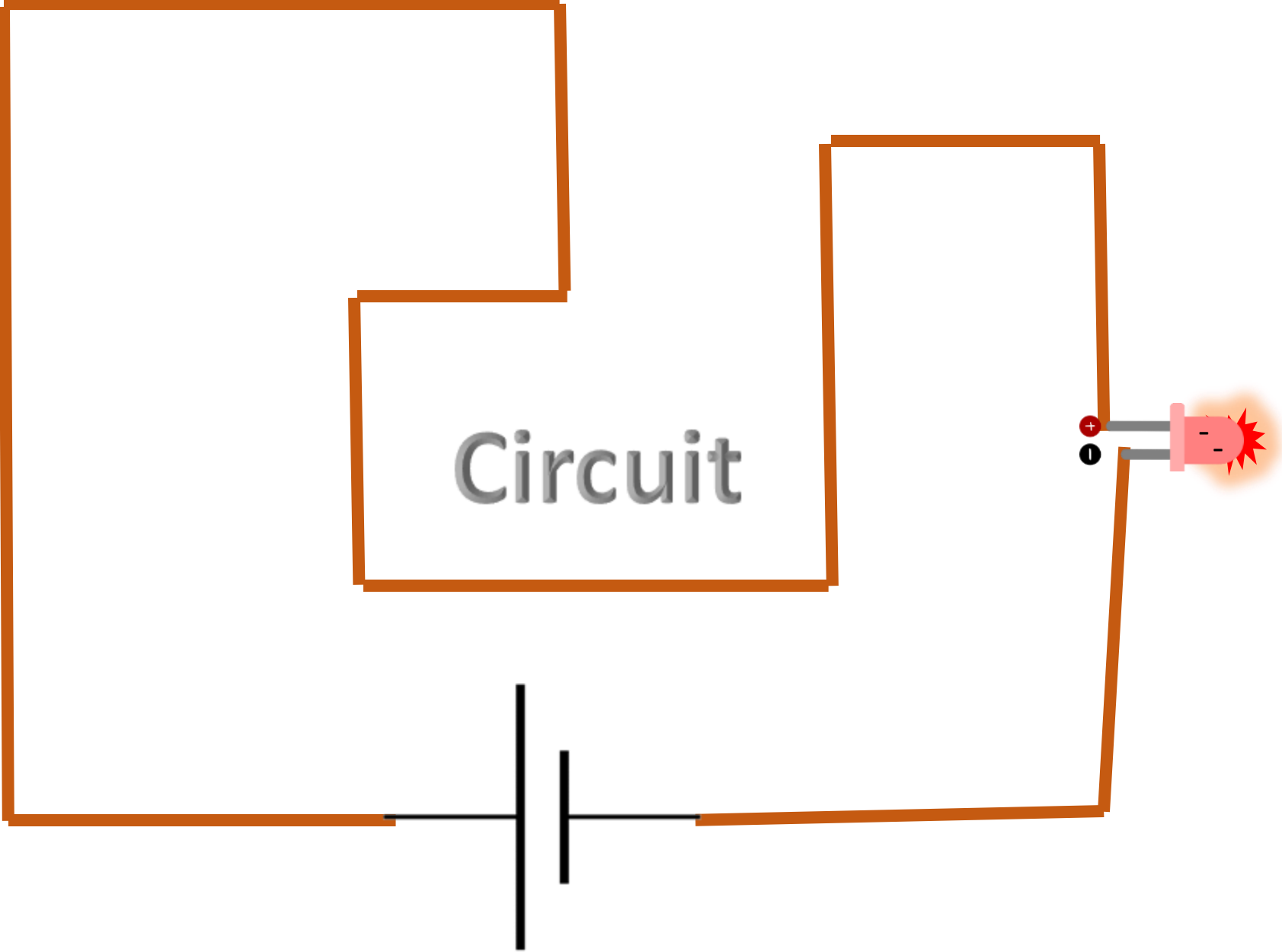

Flow of electrons = current

Closed
Circuit

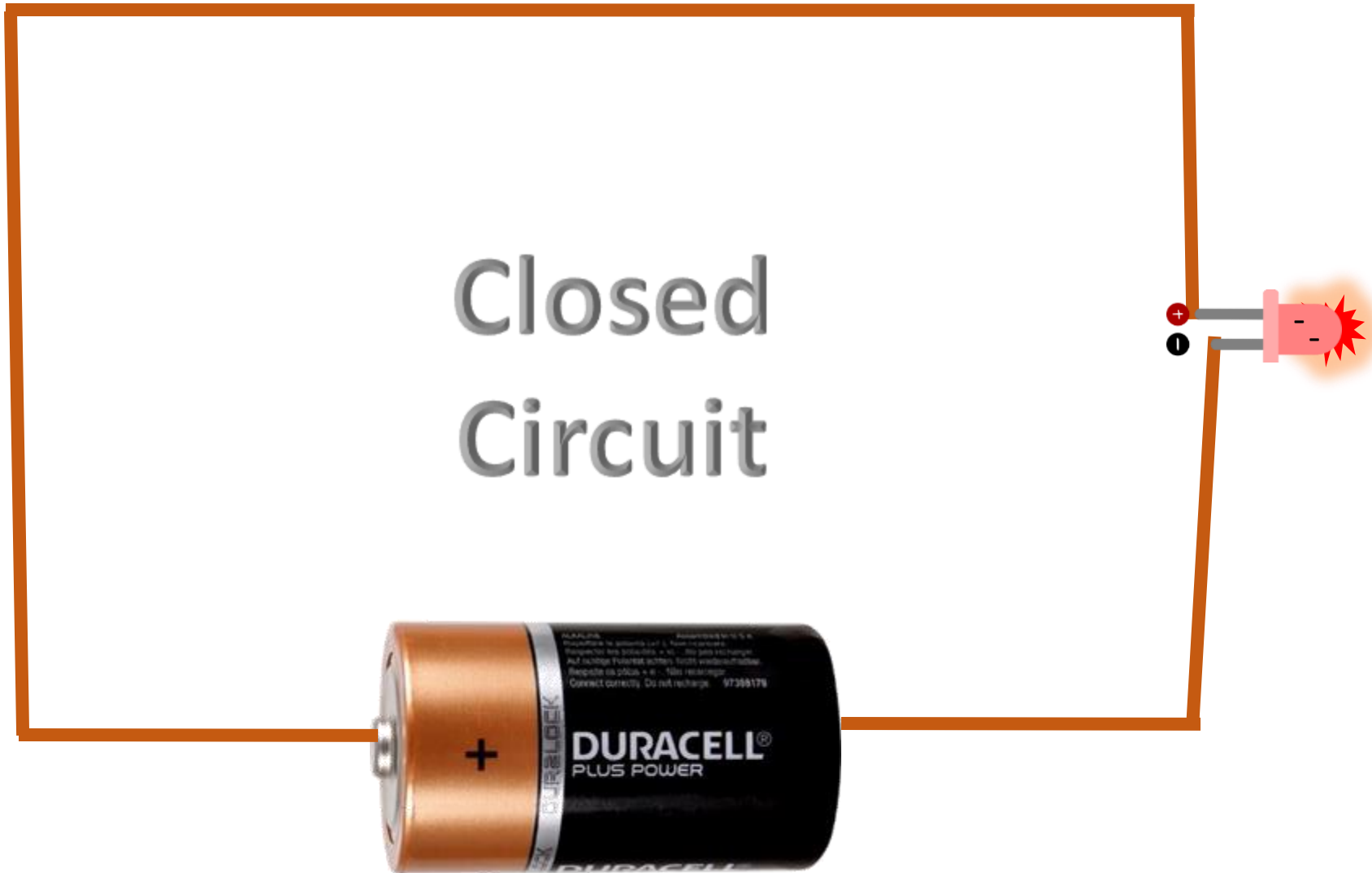

Flow of electrons = current

Open
Circuit

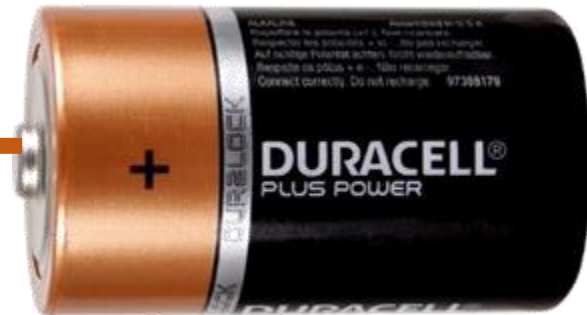

Flow of electrons = current

Closed
Circuit

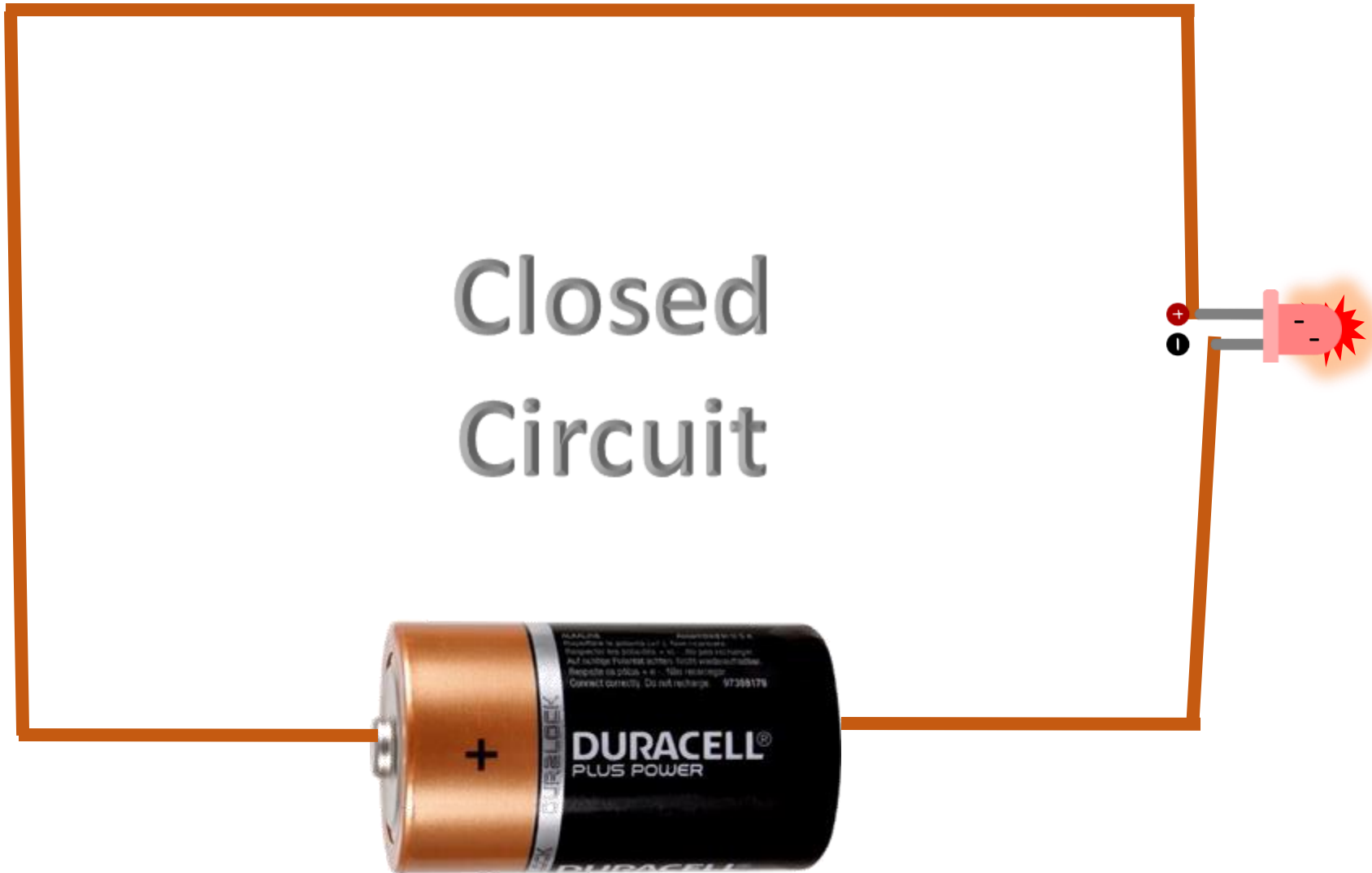

Flow of electrons = current

Open
Circuit

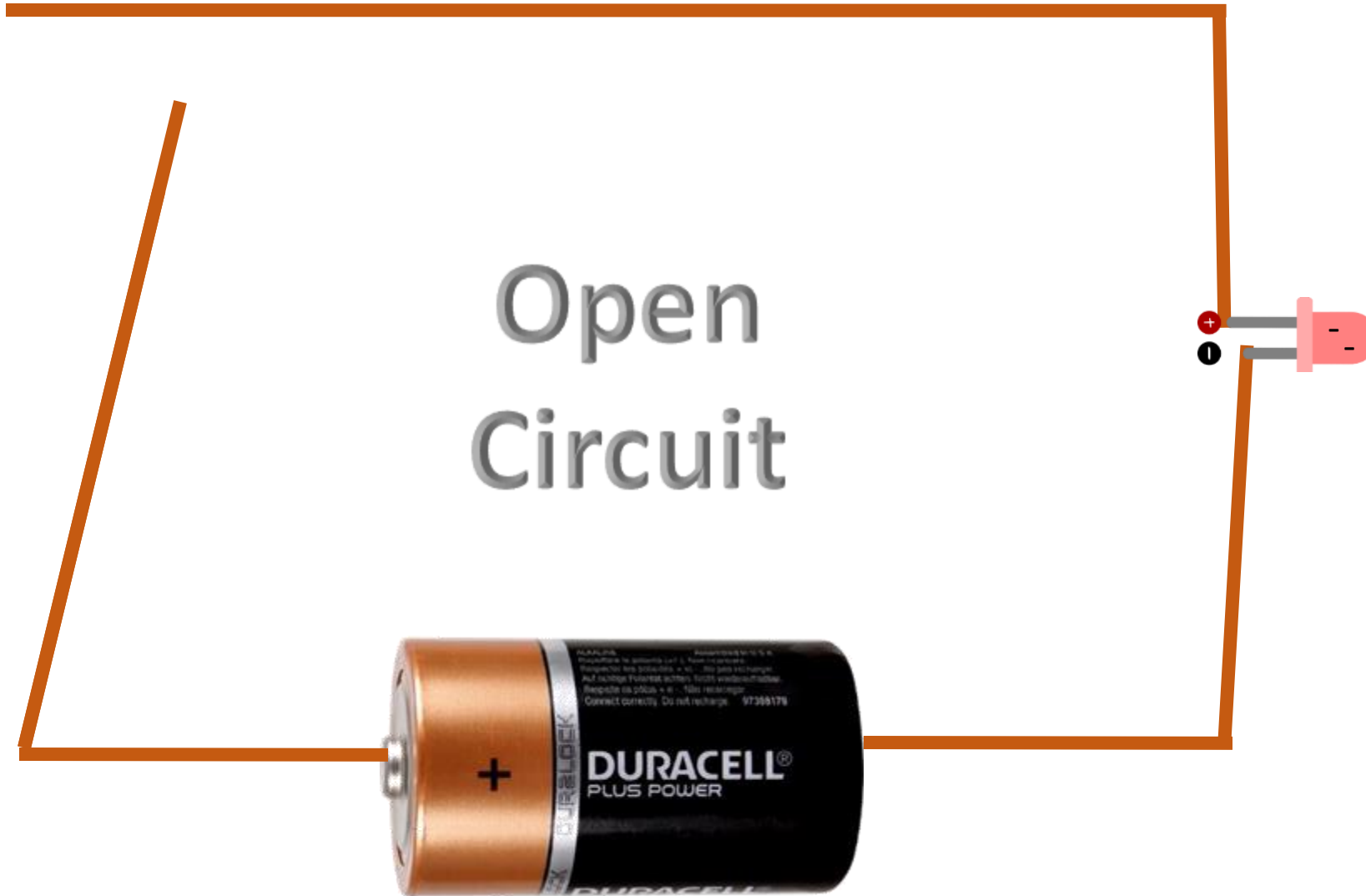

Symbol

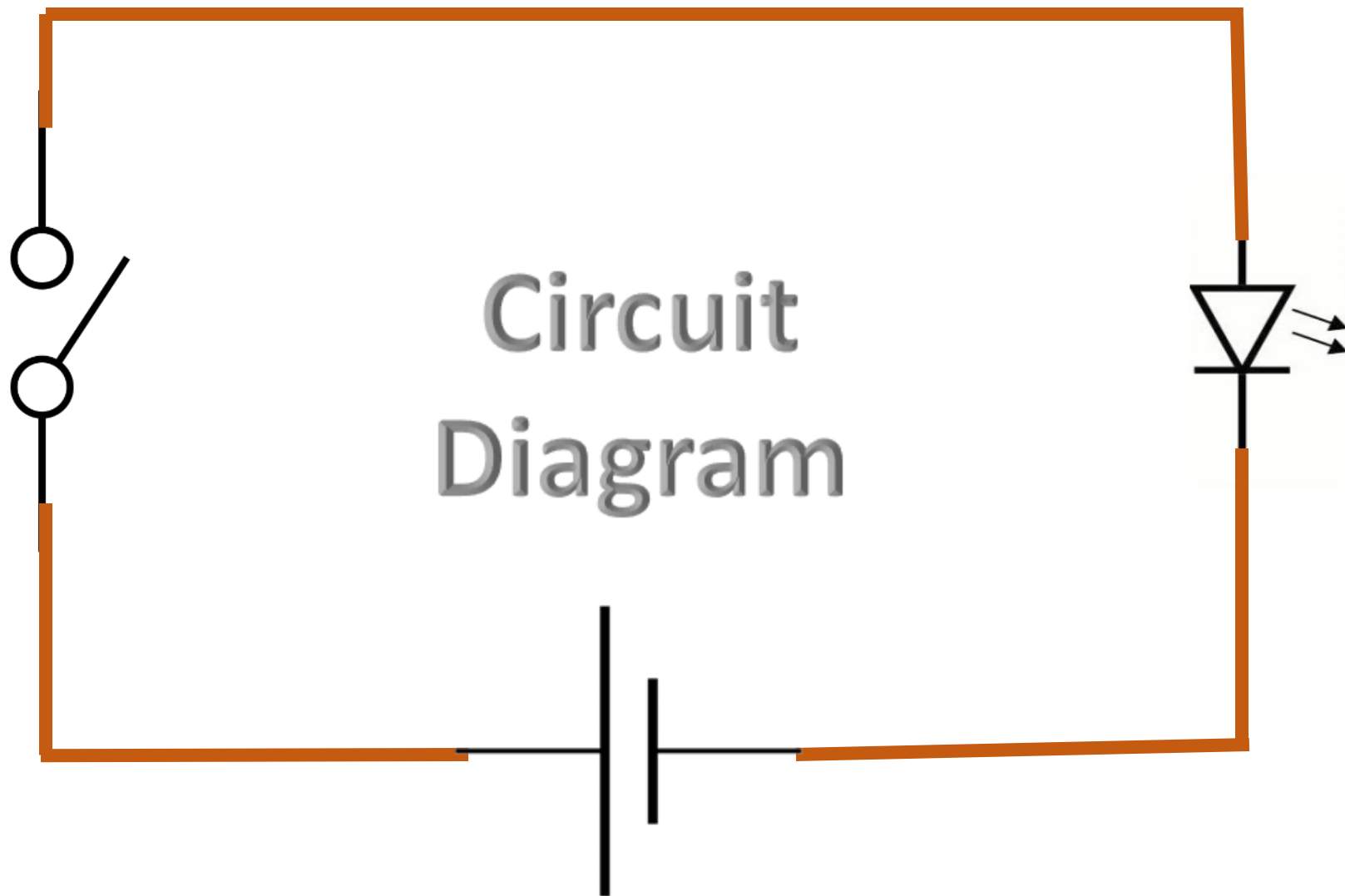

Circuit
Diagram

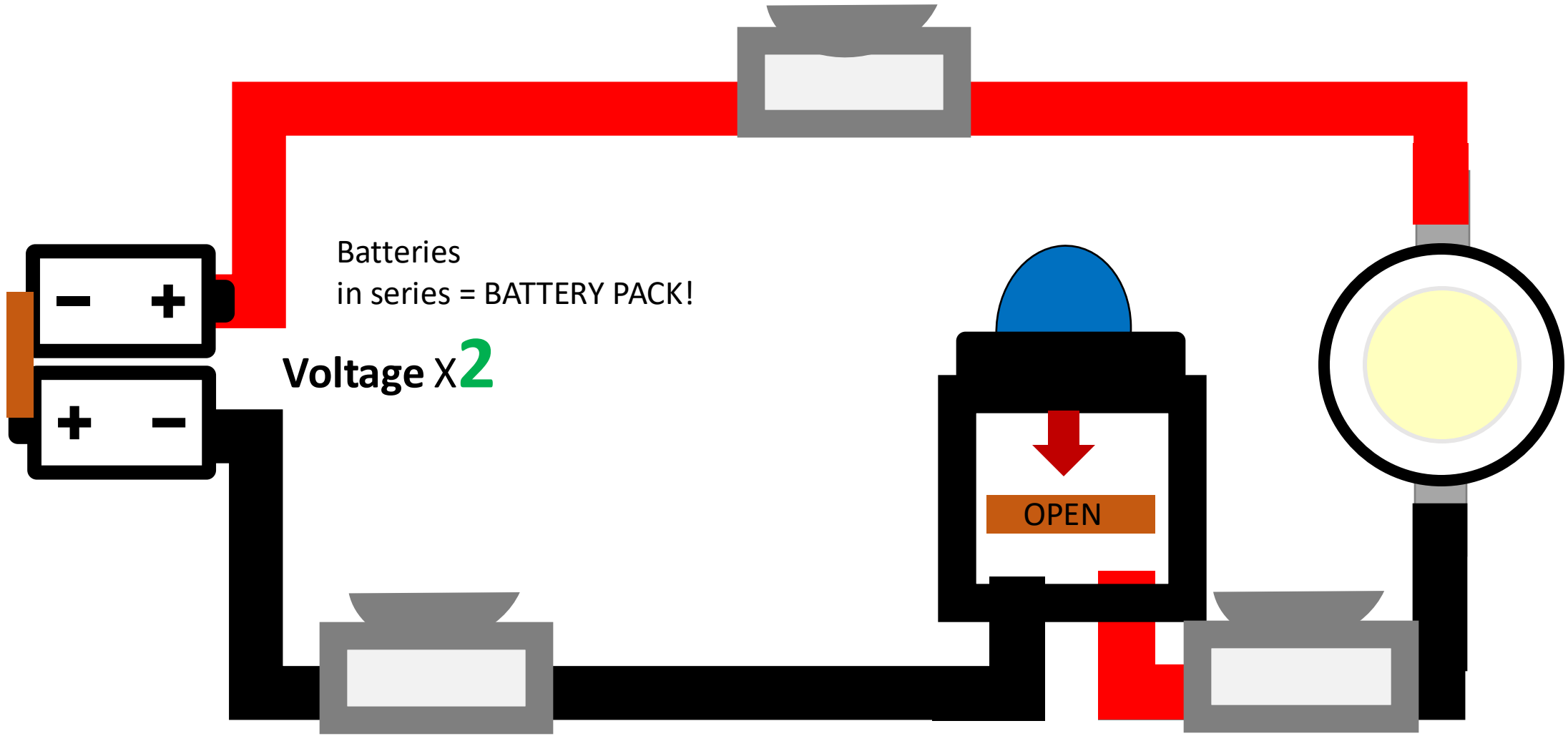

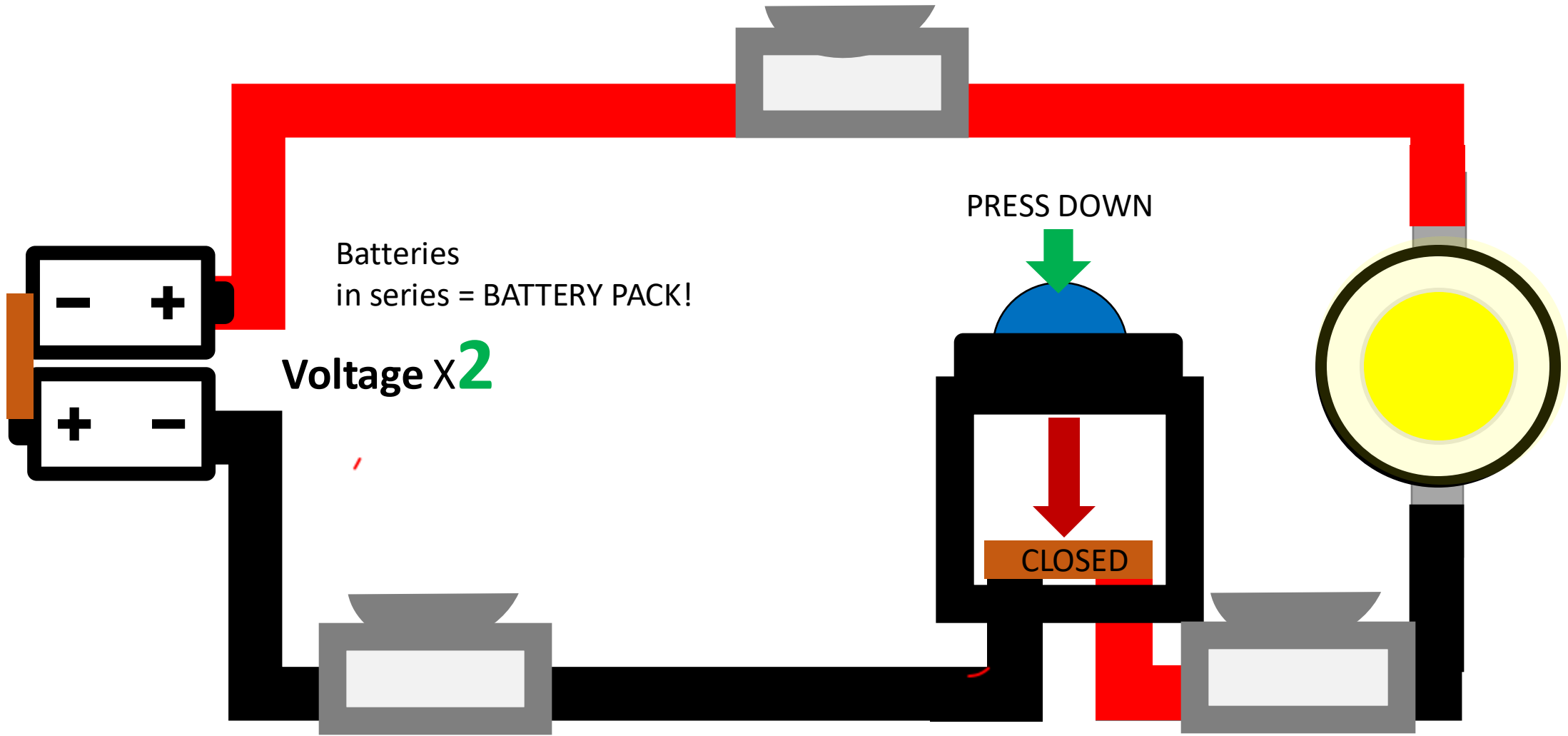



ACHIEVEMENT
UNLOCKED!!!





LET'S BUILD THE STAR
PROJECTOR!

STEP 1~4

PLASTIC CAP WITH
A HOLE

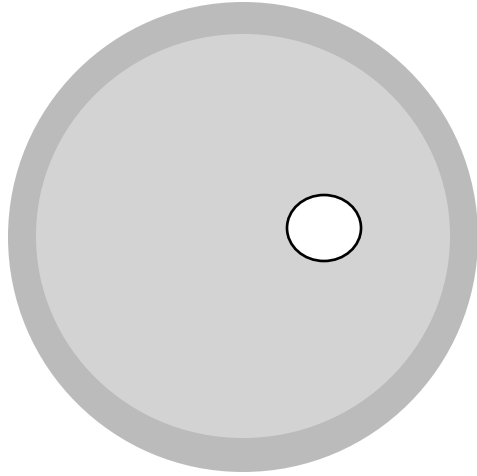

PLASTIC NUT

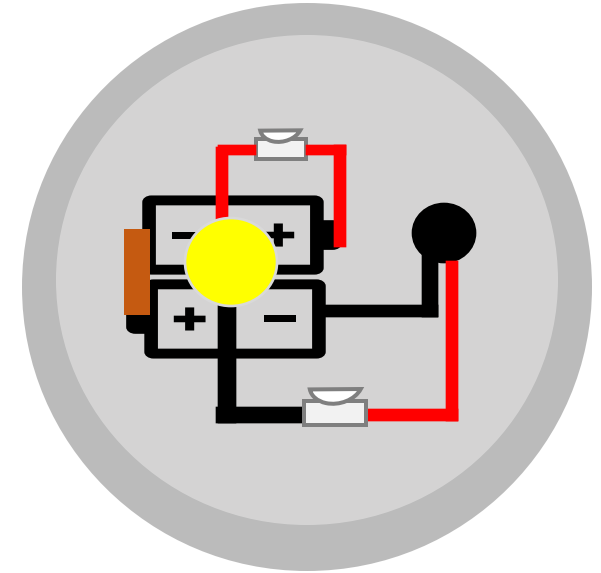
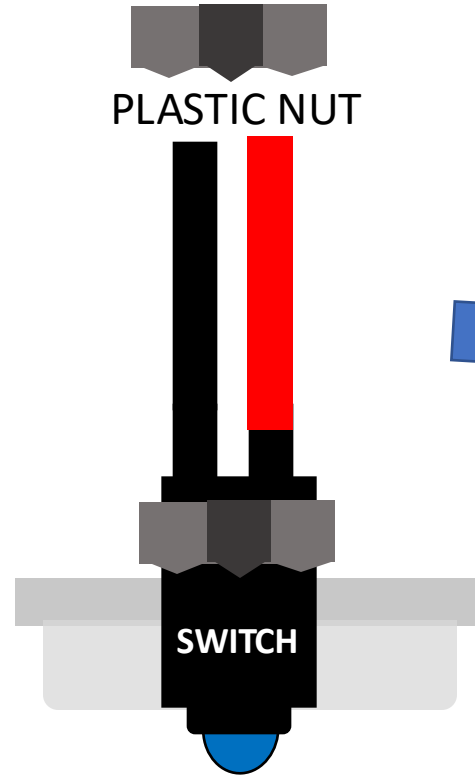

TAPE THE BATTERY
HOLDER TO THE LID. USE
BLUE TACK TO SECURE
THE LED FACE UP.

STEP 5

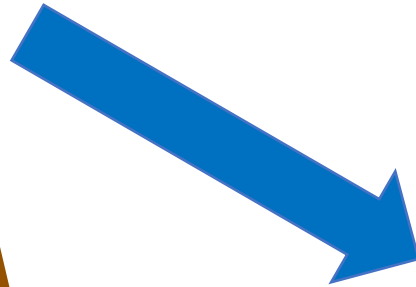
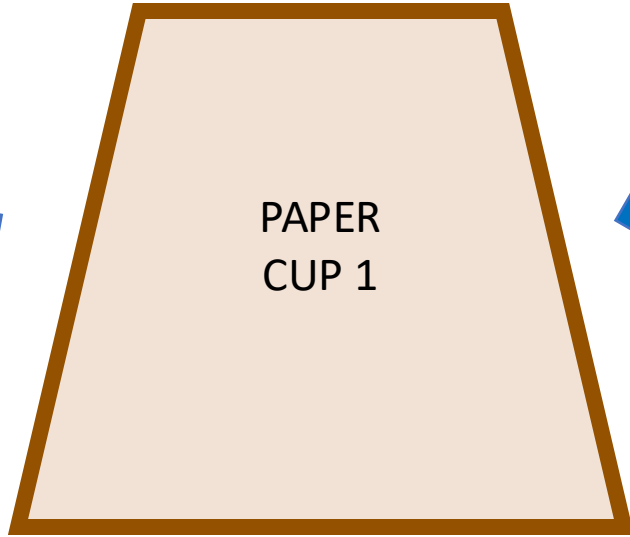
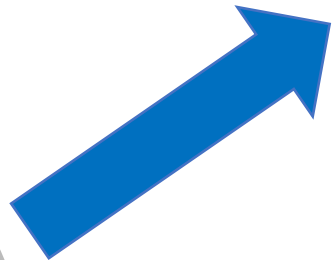
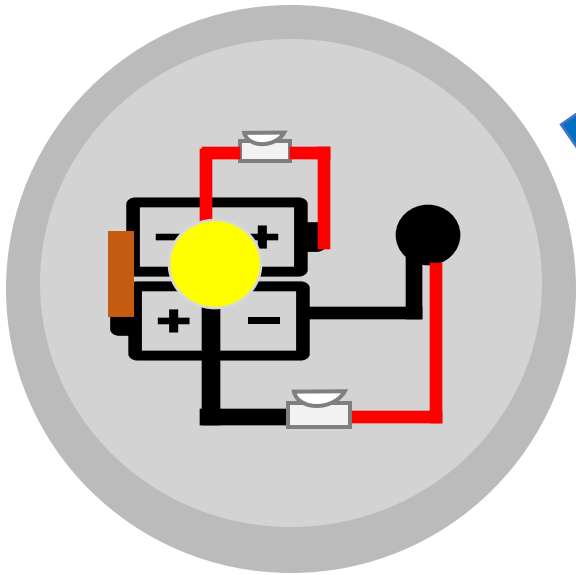

CLOSE CUP 1.

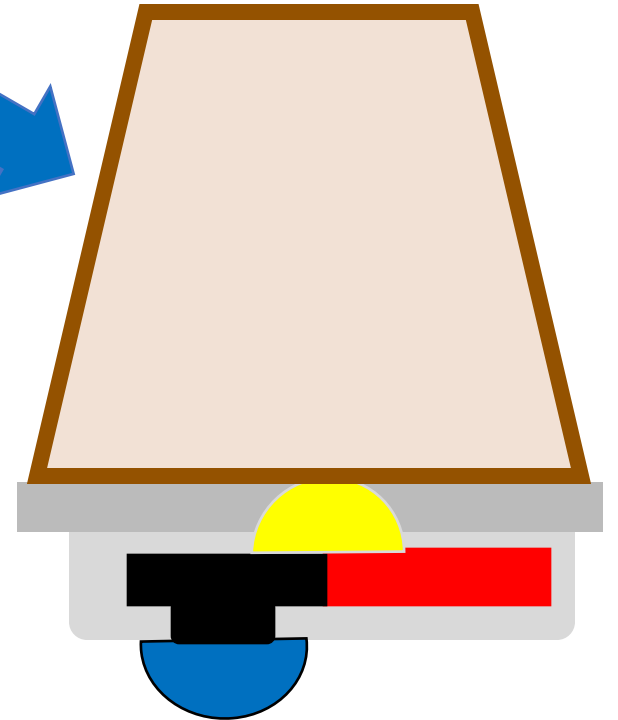

STEP 6

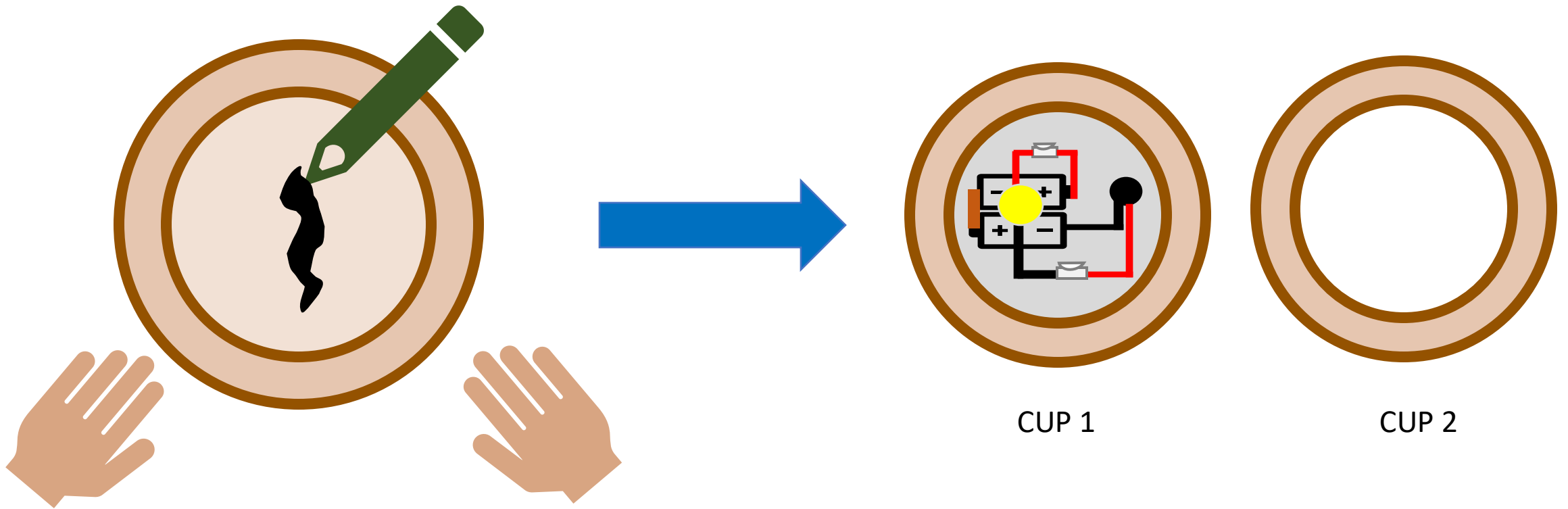

STEP 7~8

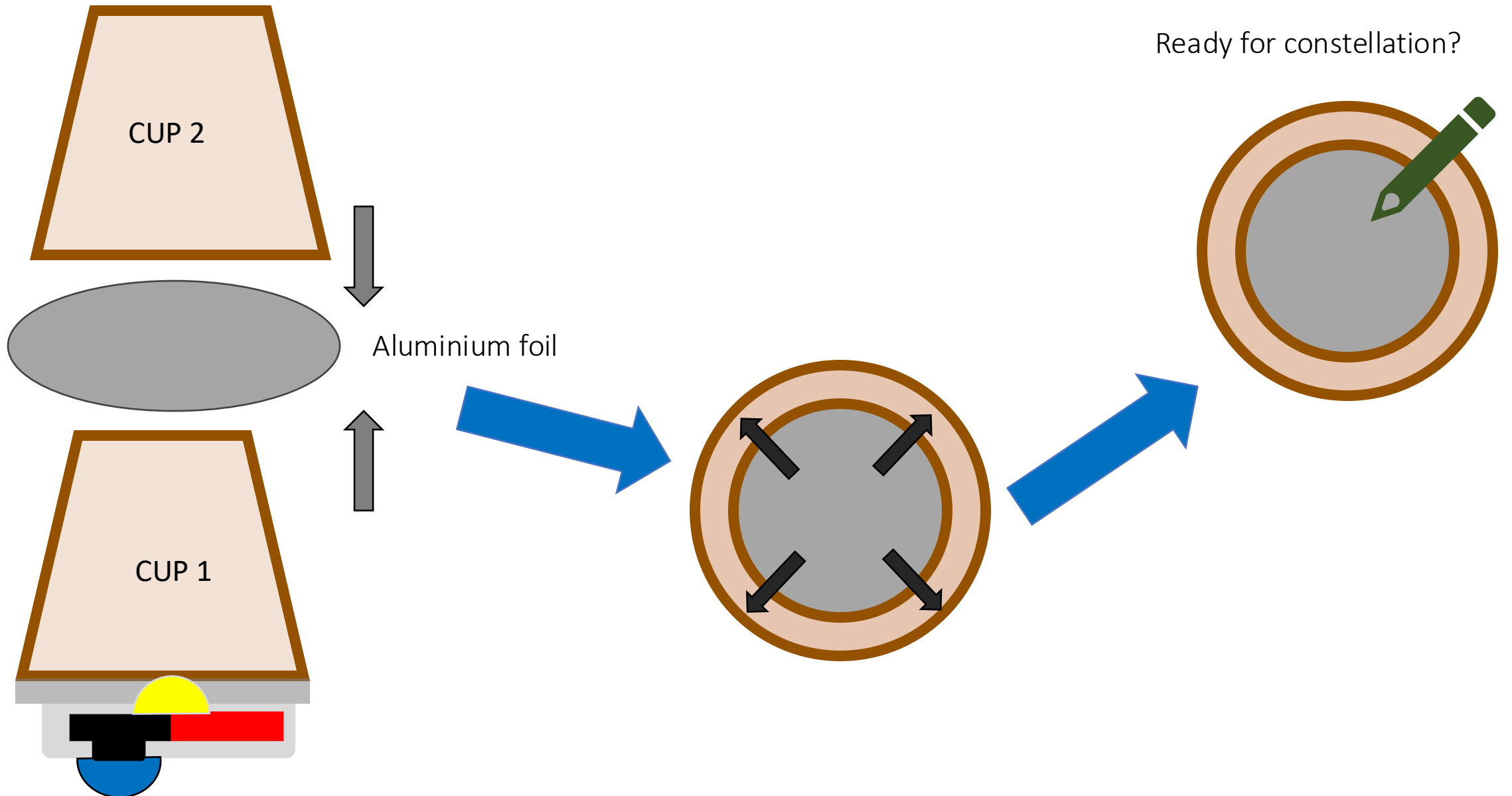

SELECT YOUR FAVOURITE CONSTELLATION OR INVENT ONE

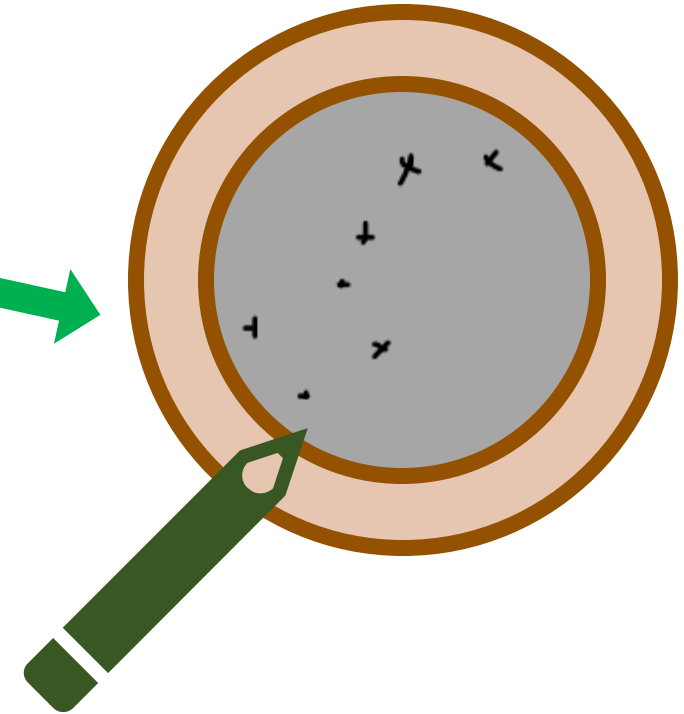
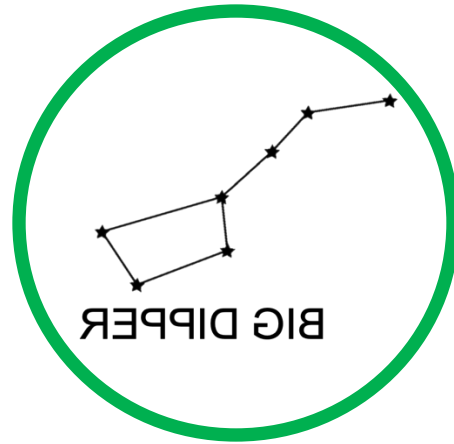
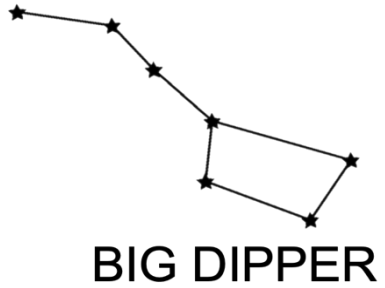

USING THE **MIRRORED IMAGE** AS A GUIDE,

COPY THE CONSTELLATION INTO THE FOIL

STEP 8

ASSEMBLY!

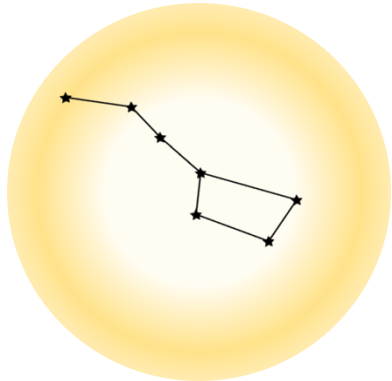
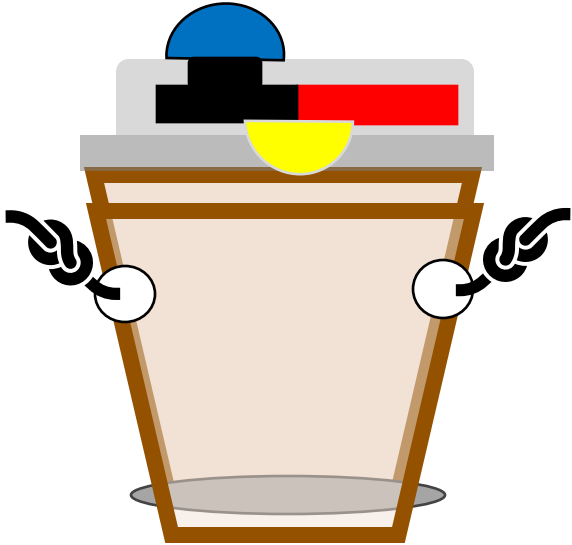
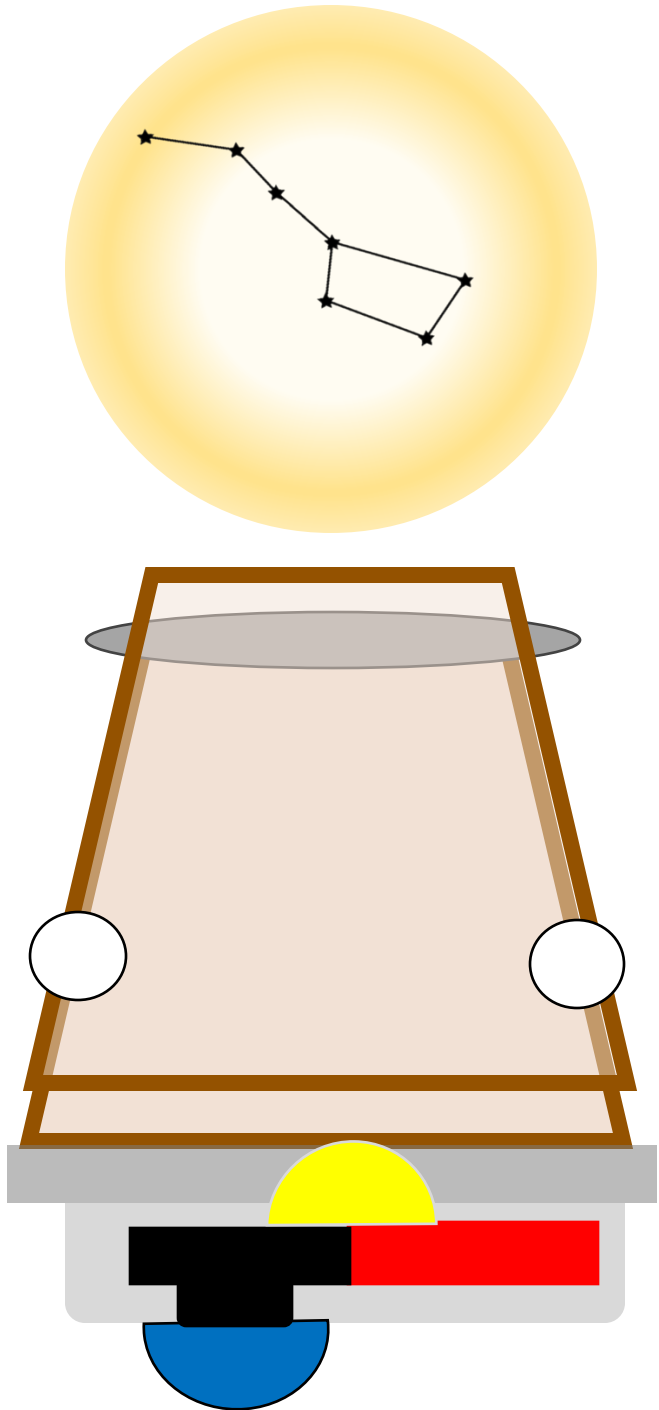



LET'S
DECORATE

DECORATION

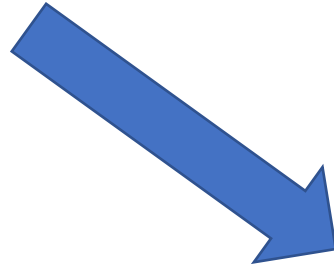

USE THE HOLE PUNCHER TO MAKE
TWO SMALL HOLES IN THE CUP

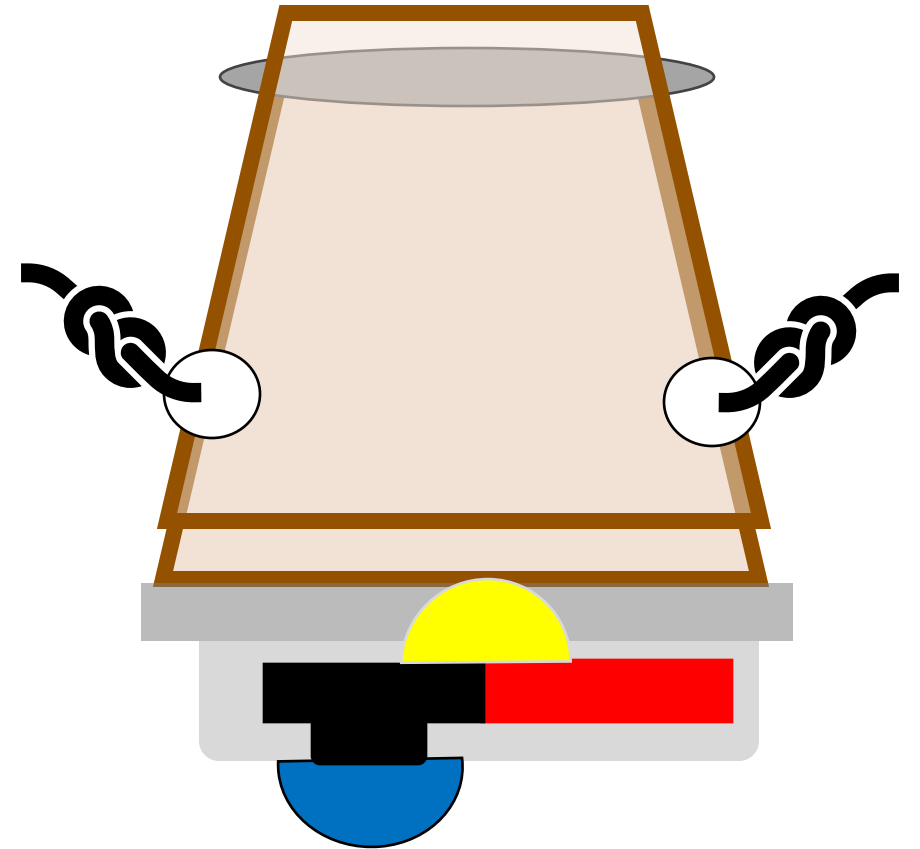



Taighde Éireann
Research Ireland



An Roinn Oideachais
Department of Education

